

# A Vision for High-Speed Rail in the Northeast Corridor

September 2010



# Introductory Letter from



**W**e are pleased to present this initial look at how Next-Generation (“Next-Gen”) High-Speed Rail service could be successfully developed in the Northeast with sustained maximum speeds of 220 mph (354 kph), three-hour trip times between Washington and Boston, and an increase in the number of train frequencies to get passengers where they need to be, when they need to be there fast, safely and efficiently. It is a vision of a realistic and attainable future that can revolutionize transportation, travel patterns and economic development in the Northeast.



As America’s intercity passenger rail service provider and only high-speed rail operator, Amtrak has a vital, leading and necessary role to play in expanding and operating high-speed rail service across the country. In this role, it is incumbent upon Amtrak to put forward a vision for a next-generation, financially viable network along the Northeast Corridor (NEC). It would provide tremendous mobility benefits to the traveling public and support the growth and competitive position of the region by investing in a vital transportation necessity whose time has come.

Just as leading countries throughout Europe and Asia are expanding existing High-Speed Rail networks and developing new systems, Next-Gen High-Speed Rail must play a role in the future of major travel corridors across the U.S. The NEC has the population and economic densities and growing demand for passenger rail service that makes it a perfect market for this type of premium rail service.

More detailed work will clearly be required, and the high-speed rail system and services envisioned in this report will evolve and be refined as a result of future studies. Nonetheless, the results show that the concept must be part of the national discussion on how true high-speed rail is advanced in America.

I hope that you will take the opportunity to review the materials in this report and participate in the collaborative planning efforts necessary to turn this vision into reality.

Sincerely,  
Joseph H. Boardman  
President and CEO





*“By investing in high-speed rail, we’re doing so many good things for our country at the same time. We’re creating good construction and manufacturing jobs in the near-term; we’re spurring economic development in the future; we’re making our communities more livable—and we’re doing it all while decreasing America’s environmental impact and increasing America’s ability to compete in the world.”*

— Vice President Joseph Biden,  
High-Speed Rail Project announcement,  
January 28, 2010

# Table of Contents

1.0	Need for High-Speed Rail in the NEC, Present and Future Transportation Networks	2
2.0	High-Speed Rail System Requirements in NEC	8
3.0	Next-Gen High-Speed Rail – Possible Alignments	10
4.0	Service Plans, Rolling Stock and Travel Times	16
5.0	Ridership and Revenues	18
6.0	Capital and Operating and Maintenance Costs	20
7.0	Financial, Economic and Other Benefits of Next-Gen High-Speed Rail in the NEC	22
8.0	Next-Gen High-Speed Rail in the NEC – Summary and Next Steps	28

## SUMMARY

Projected growth in the Northeast will substantially increase intercity travel demand, straining an already congested transportation network. The ability to expand the region’s heavily congested highway and air service networks is severely constrained. The improvements outlined in the recently-released Northeast Corridor (NEC) Infrastructure Master Plan would bring the current system to a state-of-good repair, ensure reliable service for all users, including intercity, commuter and freight, and provide sufficient capacity to meet estimated ridership demand through 2030. It would not, however, provide the improvements in travel time or service levels needed to attract or handle significant numbers of new passengers or help alleviate congestion on the region’s heavily constrained highway and air networks.

Recent international experience and numerous studies indicate that a Next-Generation (Next-Gen) High-Speed Rail system in the Northeast could be a “game-changer” in terms of high-quality, world-class rail service to meet this increased travel demand in an efficient, cost-effective and sustainable manner. The NEC is the nation’s most important passenger rail corridor. Amtrak’s

pioneering high-speed rail service experience, the NEC’s high-density “megaregion” development pattern and connecting commuter and local rail networks, are critical elements to the successful Next-Gen High-Speed Rail operations.

This report presents a possible concept for Next-Gen High-Speed Rail in the NEC, with new dedicated high-speed rail alignments, stations and equipment that can provide significant travel time savings and attractive premium service by rapidly connecting the Northeast’s major hub cities (Boston, New York, Philadelphia and Washington, D.C.) along with its smaller cities, airports and suburban hubs. Upon completion in 2040, Next-Gen High-Speed Rail ridership would be roughly 5 times current Acela levels, with overall NEC network ridership at 3-4 times current levels. The system’s construction would support 44,000 jobs annually over the 25-year construction period and approximately 120,000 permanent jobs, while generating an annual operating surplus of approximately \$900 million. The economic value of improved intercity mobility, fewer highway accidents, reduced air service delays and other benefits would exceed the overall costs of the system’s development.



# 1.0 Need for High-Speed Rail in the NEC, Present and Future Transportation Networks

The changing economic geography of the U.S. over the last 50 years has resulted in the modest growth of its core cities and vast increases in the surrounding suburban and exurban rings that form the nation's major metropolitan areas. Experience nationally and worldwide indicates that the next half-century will be defined by the emergence of "megaregions" – extended corridors of interconnected metropolitan areas with shared economic sectors and linked infrastructure. America 2050, an infrastructure research and policy initiative, has identified eleven such megaregions in the U.S., ranging from 200 to 600 miles in length, where roughly three-fourths of the nation's population lives, and an even greater percentage of its Gross Domestic Product (GDP) is produced. Of these, the Northeast megaregion, which is organized around five major metropolitan regions – Boston, New York, Philadelphia, Baltimore and Washington, D.C. – is the densest and most economically productive. Its 50 million residents produce 20% of the nation's total GDP on just 2 percent of its land mass. Its

per capita GDP, 19% above the national average in 1980, rose to 27% above by 2009. Its population density is roughly 12 times the national average.

This juxtaposition of high density and high productivity is no coincidence. High-value activities – corporate headquarters, global finance and business services, biomedical facilities, world-class universities, media centers and cultural institutions – need to be in relatively close proximity in order to share large, diverse labor markets and the opportunity for vital face-to-face interactions. The Northeast's five major interconnected metropolitan regions depend on the ability to accommodate frequent business travel among them, often without the cost or inconvenience of overnight stays, thus requiring efficient, reliable and convenient transportation connections.

Projections indicate that demographic and economic growth in the Northeast will remain strong over the next 30 to 40

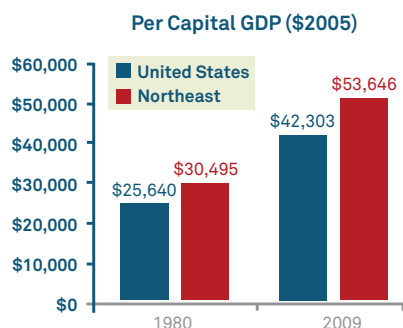
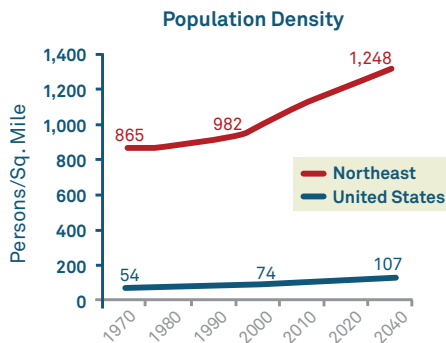

years. Present “baseline” projections by Moody’s Economy.com (extrapolated to 2040 and 2050 for this report) indicate that the four largest metropolitan regions – Boston, New York, Philadelphia and Washington, D.C. – presently account for over 80% of the megaregion’s employment and population, and they would account for roughly the same amount in the future. The Washington, D.C. metropolitan area would have the highest growth rate of the four hub cities: it represents approximately

*Largest U.S. Metropolitan Areas (2009)*

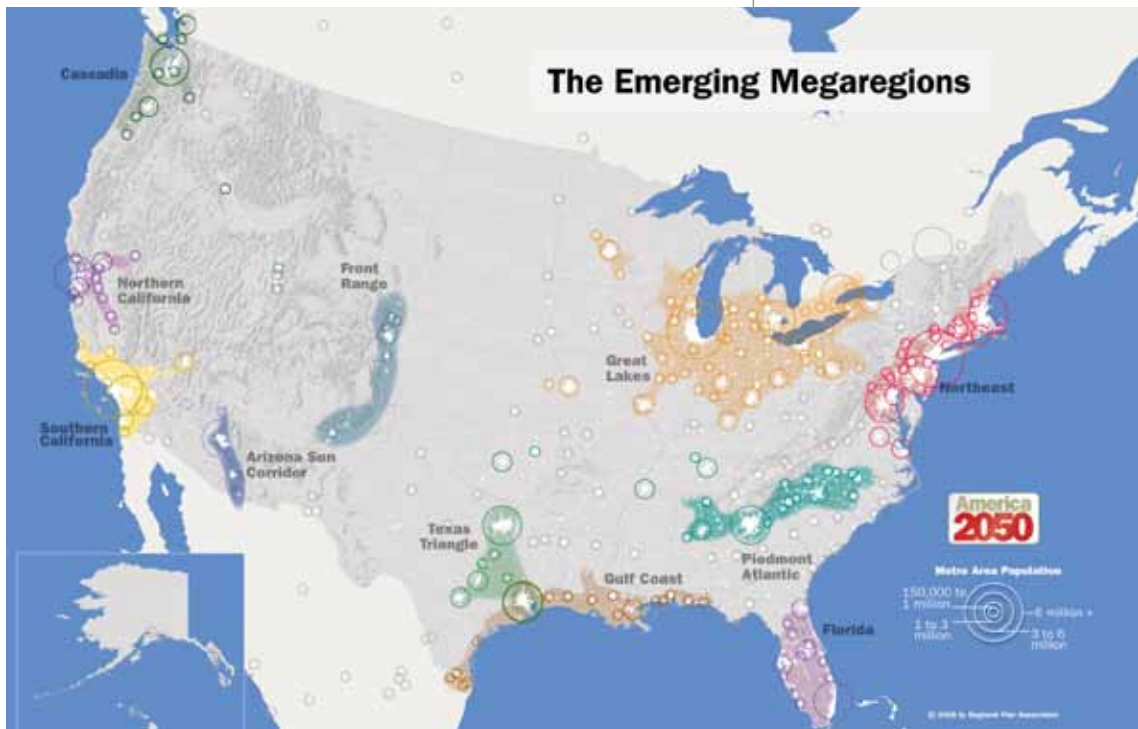
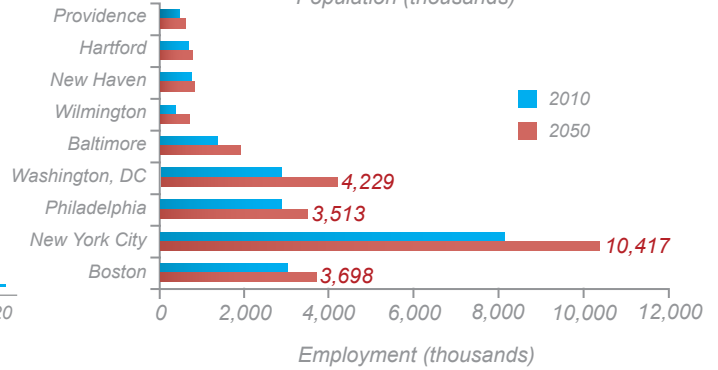
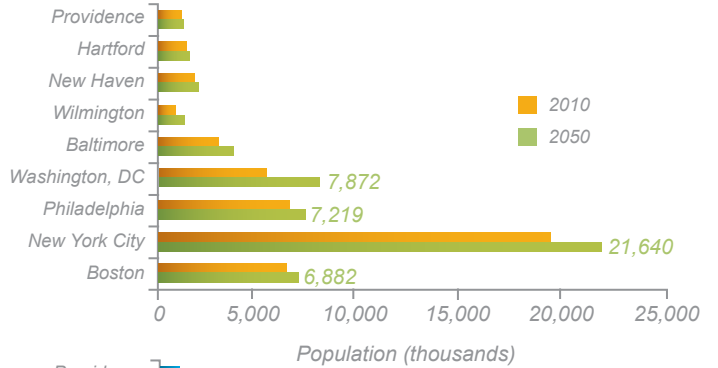
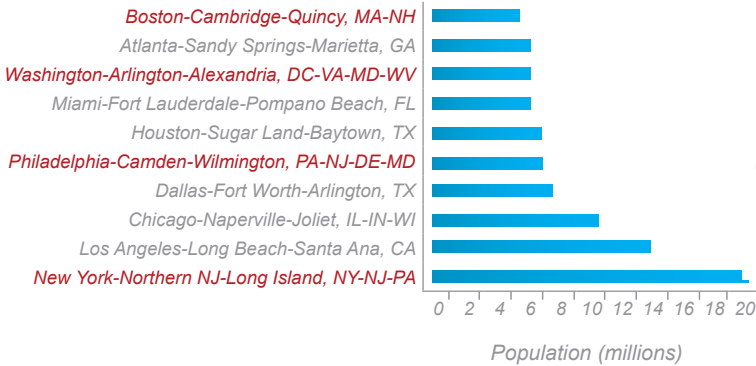

11% and 12% of the NEC's 2010 population and employment, respectively, but would generate 32% and 22% of the projected Northeast growth in those areas. The major question is how the trips generated by this metropolitan and regional growth are going to be handled.

Throughout much of the 19th-century and well into the 20th century, nearly all intercity travel was conducted via a comprehensive, privately-financed railroad network. Railroads remained the predominant intercity transportation mode, enjoying record ridership levels during World War II. However, auto use was on a steady rise beginning in the 1920s, while passenger rail use began a precipitous decline

in the post-War years that accelerated over the 1950-1970 period. Huge national public investment in highways and air travel infrastructure strengthened the move toward auto and air travel. Major land use and demographic shifts further increased auto ownership and use, and focused population and employment increases in areas less served by local transit and intercity rail services. The creation of Amtrak in 1970 and gradual increases in investment slowly stemmed the decline in passenger rail use, but public investment continued to strongly favor highway and air travel modes. Lately, based in part on experiences overseas, the potential role of high-speed rail systems in providing sustainable regional mobility has drawn wide recognition.

Total Public Expenditures (nominal millions of dollars)						
	1956	1966	1976	1986	1996	2004
Highways	6,999	12,813	24,235	50,370	80,410	120,424
Aviation	334	1,332	3,763	8,846	17,609	28,621
Rail	8	26	1,459	908	1,023	1,534

Source: Congressional Budget Office, 2009.

Northeast Corridor Travel Volumes (Millions of Annual Trips)

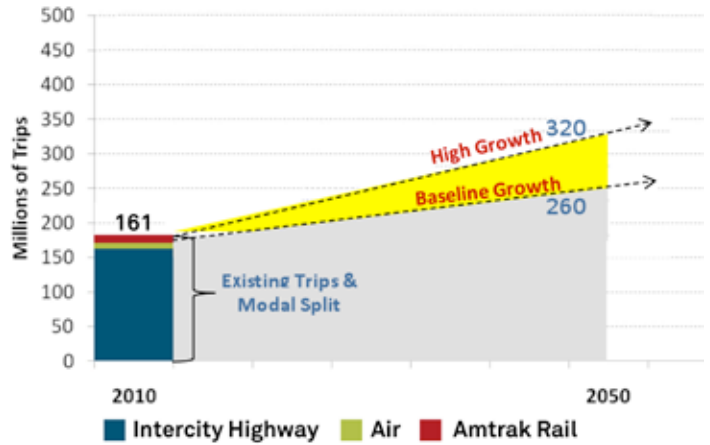

Annual Passenger Miles for Public Travel Modes: 1960-2000

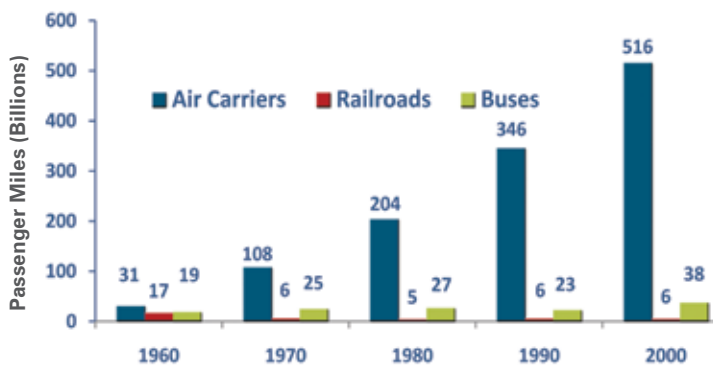

Source: USDOT, BTS (2006)

Share of 2010 NEC Intercity Trips

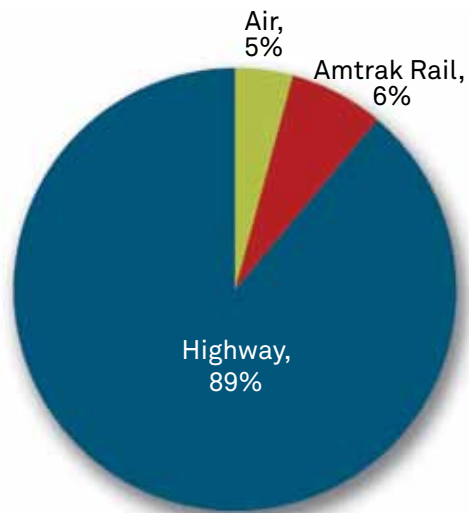

## Projected Demand for Intercity Transportation in the NEC

As previously noted, the Northeast’s significant growth projections will translate to an equally large rise in total trip-making in the corridor. Highways presently handle approximately 89% of the roughly 160 million annual intercity trips in the Northeast Corridor (NEC) study area, with air travel (6%) and Amtrak rail (5%) handling the remainder (intercity trips are those 75 miles or longer). With the projected population and employment growth, this number will grow by almost one-third, putting tremendous stress on the overall transportation network.

## Current and Projected Status of NEC Transportation Networks

**Highways** — Increasing congestion and lack of capacity on highways threaten the continued high economic productivity in the Northeast. Urban road congestion conditions in the Northeast, already among the worst in the nation, have significantly deteriorated over the last two decades. In the five major metropolitan regions of Boston, New York, Philadelphia, Baltimore and Washington, D.C., total hours of congestion increased by 24% between 1990 and 2007, with the average commuter experiencing a 60% rise in traffic delays over that period, and resulting in millions of gallons of additional fuel consumed annually. Due to the largely unbroken stretch of

Change in Congestion on Key NEC Highways: 2002 - 2035

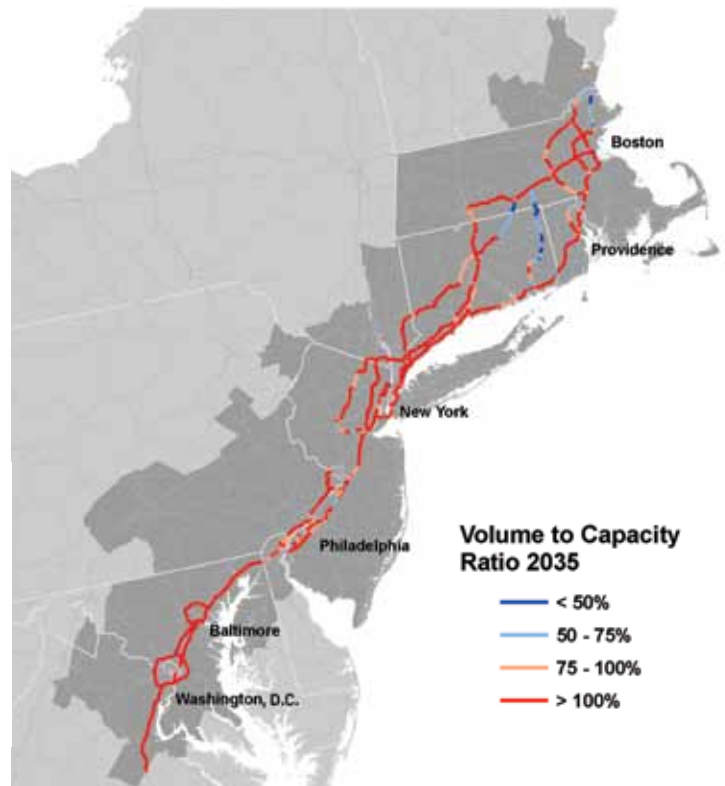
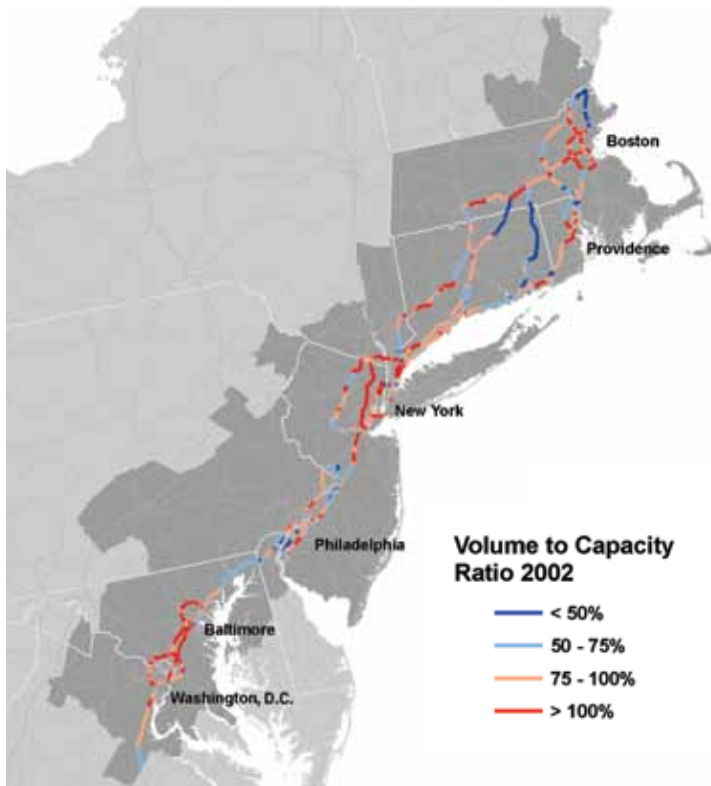



urbanized land along the NEC, this metro-area congestion impacts both local commuters and intercity travelers. Analyses of key north-south highways along the corridor by the Federal Highway Administration indicate that already high congestion levels measured in 2002 will increase to the point of corridor gridlock by 2035, creating serious local/regional mobility problems in the corridor's urban areas and similar challenges for intercity travel. Annual expenditures in the \$25 billion range would be needed to make any headway in dealing with this congestion, according to a recently released report by the I-95 Corridor Coalition, "A 2040 Vision for the I-95 Coalition Region," and any further expansion of highways in urban areas faces substantial practical and political difficulties. More importantly, from the local to the national level, there is a growing understanding that more highway lanes are not a sustainable transportation solution in terms of energy efficiency, environmental impacts and economic competitiveness.

The proposed Next-Gen high-speed system, at full capacity, would add intercity travel capacity equal to approximately 1,900 lane-miles of Interstate highway, but with 220 mph service and convenient, downtown-to-downtown connections.

**Air Travel** — Northeast airports are among the nation's most congested, leading to extensive delays with both regional and national consequences. In 2007 (the most recent peak travel year before the economic downturn), the Northeast had the nation's four most delay-prone airports and six of the worst nine. Although Amtrak handles a growing majority of the total air/rail travelers in the New York-to-Washington, D.C. and New York-to-Boston markets, intra-regional air travel in the Northeast is still strong. Approximately one-third of departing flights from the three New York metropolitan airports have destinations within 500 miles, including 200 daily flights heading for destinations along the NEC. Every major airport in this megaregion contains at least one other megaregion city among its top ten destinations.

While the efficiency and appeal of air travel is greater for longer-distance travel (> 500 miles), much of the corridor's airport and airspace capacity is dedicated to shorter, intra-regional trips. Growing demand for longer-distance domestic and international air travel puts further pressure on these constrained aviation facilities, with limited ability to create more service "slots" in congested air spaces like the New York

Average delay at 34 Major Airports in 2007 (in minutes, rounded)

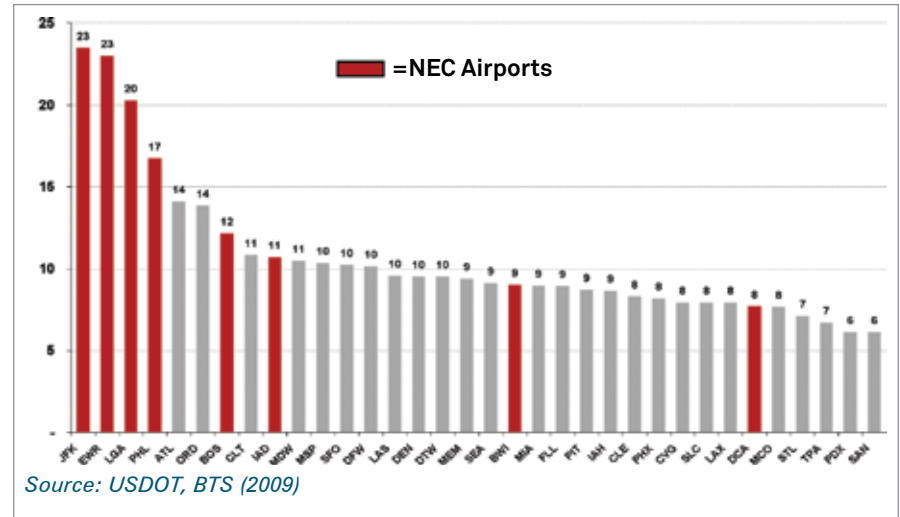

Source: USDOT, BTS (2009)

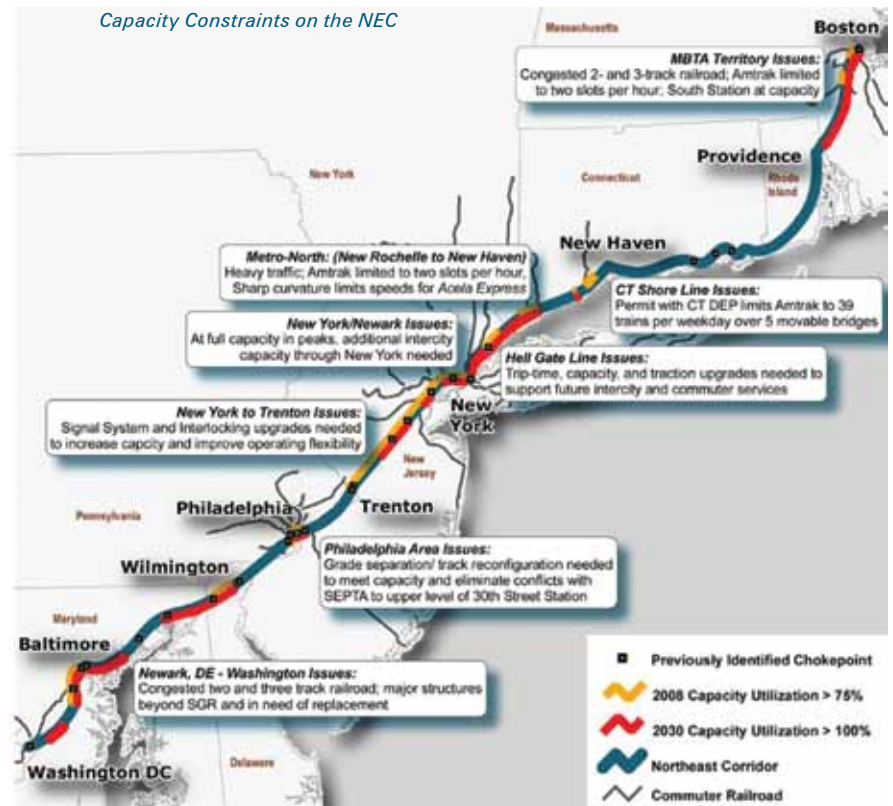

Source: NEC Master Plan Capacity Utilization



metropolitan area. A shift to other modes – especially fast, frequent, high-quality intercity rail – for the shorter (100-500-mile) intra-corridor trips is essential, freeing up scarce air transport capacity for higher-value transnational and international flights.

**Rail Travel** – The NEC is the nation’s most congested rail corridor, and one of the highest volume corridors in the world, serving Amtrak’s 13 million annual passengers as well as roughly 250 million annual commuter rail passengers and approximately 50 freight trains per day. On-time performance has been affected by a lack of capacity along many stretches, especially where its operations overlap with regional commuter traffic. In the New York metropolitan region, some areas are operating at 100 percent capacity, resulting in significant delays from even minor operating disturbances. The corridor includes a mixture of aging infrastructure, much of it built 80 to 150 years ago, that will require extensive repair to just keep it running safely and efficiently. The 2010-2030 NEC Master Plan developed by Amtrak, in consultation with states, commuter rail and freight operators, and other agencies, calls for \$52 billion in investments to cover needed system repair and upgrades and some capacity enhancements to help handle the projected 60% increase in intercity and commuter trips in the corridor by 2030 alone. Unfortunately, whatever added capacity is realized under this plan would be exceeded by 2030, limiting Amtrak’s ability to add service, especially higher-speed Acela trains which utilize more track capacity due to their higher speeds.

### Potential Responses to these NEC Challenges

Robust growth is projected for the Northeast megaregion, leading to a parallel surge in intercity travel demand that the available highway, air and rail networks will be unable to meet under present travel patterns. Highways are heavily congested, difficult to expand, and recognized as ineffective in meeting the demand for efficient, reliable and attractive

travel in the key 100-500-mile travel market. Air travel is essential to the corridor’s growth and competitiveness, but a shift away from shorter intraregional markets is needed to provide scarce air capacity for longer-distance markets. Even given proposed Master Plan improvements, Amtrak and other rail service providers using the NEC will not have the capacity to meet the projected demand, with very limited ability to attract a larger share of intercity travelers.

The economic growth projections for the Northeast (approximately 1.8 percent annually over the next 40 years) are only potential targets; they will require extensive public and private sector actions to be realized, and meeting critical intercity travel needs is one of these actions. The Federal Railroad Administration (FRA)’s Commercial Feasibility Study, the 2050 vision study of the National Surface Transportation and Revenue Study Commission, and other research make it clear that Next-Gen High-Speed Rail is the logical next step to creating a higher-performing overall transportation network capable of meeting this demand, especially in the NEC. Many competing megaregions around the world have made major ongoing, and often long-standing, investments in this critical mode. Recent actions at the Federal level have also shown that the nation’s commitment to this technology has begun in earnest.

The NEC has all the characteristics to make Next-Gen High-Speed Rail a success:

- Major metropolitan areas with sufficient population and economic densities to support this mode;
- Well spaced city pairs within an overall megaregion;
- Extensive local transit, commuter and other intercity rail services to feed into the network; and
- A record of attracting riders to initial high-speed rail services.

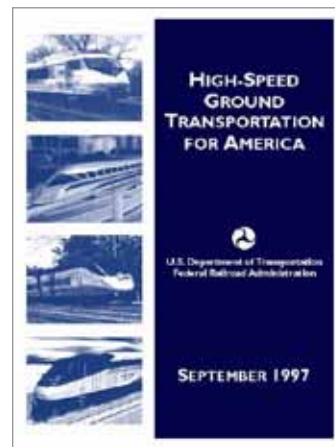

# 2.0 High-Speed Rail System Requirements in NEC

## Next-Gen High-Speed Rail System Requirements in the NEC

**N**EC Acela service represents the only true “Emerging High-Speed Rail” operation in the U.S., with 165-mph equipment and maximum operating speeds of 150 mph – speeds rarely met due to track limitations, the number of stops, and capacity demands from other NEC rail operations. The FRA’s 2009 High-Speed Rail Strategic Plan envisioned a gradual evolution of U.S. high-speed rail operations, with the roll-out of other 110 mph “Emerging High-Speed Rail” operations and new 150 mph “High-Speed Rail Regional” systems, leading to “High-Speed Rail Express” operations – true Next-Gen service equivalent to existing and developing systems around the world.

## Potential Markets and Travel Time Goals

The study team identified the travel time, frequency, passenger comfort, pricing and other factors needed to attract NEC travelers to Next-Gen High-Speed Rail service. High-speed rail experience from similar corridors around the world

provided further evidence of what travel time and service characteristics were needed to succeed. The key travel time goals were for services among the major travel centers – the “Hub Cities” of Boston, New York City, Philadelphia and Washington, D.C. Convenient travel to intermediate cities, suburban intermodal stations and airports along the corridor would also be critical to any successful Next-Gen High-Speed Rail operation. The more stops between the major hubs, the more difficult to meet travel time goals.

It was clear from Amtrak’s own Acela service experience and from successful Next-Gen High-Speed Rail corridors around the world (Paris - Lyon, Madrid - Seville, etc.) that such services would need:

- Travel times and train frequencies to create a highly competitive downtown-to-downtown option, especially as an alternative to air travel; and
- World-class high-speed rail train sets capable of 220 mph top speeds that allow travel time goals to be met and provide a high level of passenger amenity, and convenient and attractive stations.

High-Speed Rail Service Categories and Examples of Next-Gen High-Speed Rail

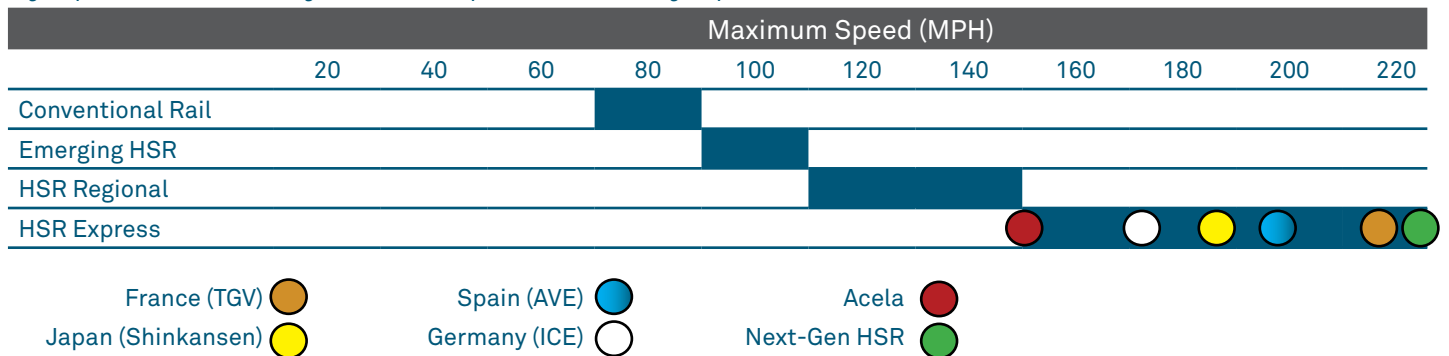

Projected NEC Next-Gen High-Speed Rail Markets

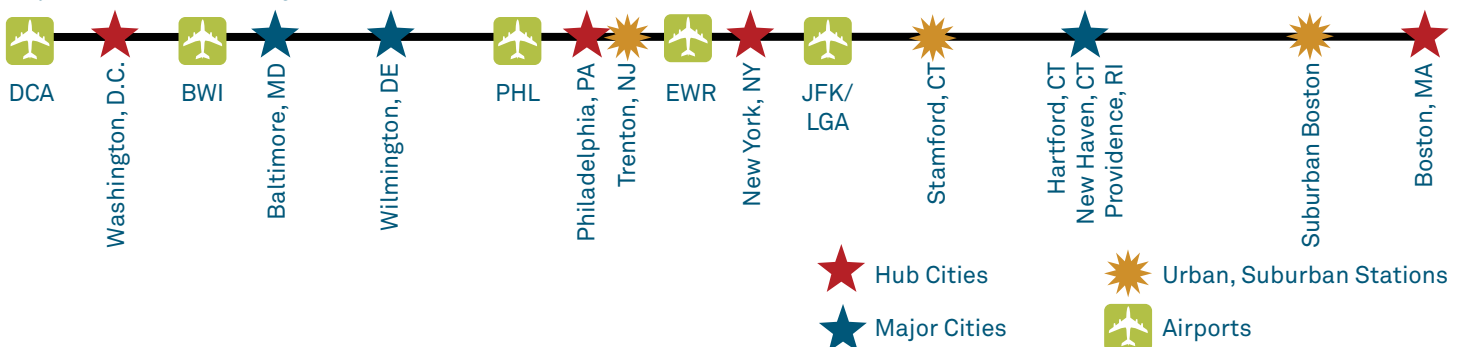

High-speed rail equipment meeting these top-speed and related performance requirements is a proven technology in commercial operation worldwide. With market sensitivity tests indicating that major travel time reductions between the Hub Cities would be required, travel time goals of **1 hour 30 minutes for New York City-to-Washington** and **2 hours for New York City-to-Boston** were established – roughly a 45% reduction in both markets.

Successful high-speed rail operations around the world have commercial operating speeds (average speeds including time in stations) of 130-140 mph. To meet these aggressive NEC travel time goals, commercial operating speeds of roughly 140 mph would be needed, compared to 62 mph (New York City-Boston) and 86 mph (New York City-Washington) under present Acela operations.

### Alignment Constraints

Next-Gen High-Speed Rail systems require dedicated tracks with stringent design criteria to ensure safe and comfortable operations. While the track’s vertical grade can be somewhat

steeper than traditional rail, its curvature limits are much more restrictive (minimum 3-mile radius curves vs. ½-mile radius for traditional commuter rail track), and even more gentle curves required to reach and maintain higher-end speeds. To further offset the force effects experienced on curved sections at very high speeds, high-speed rail tracks can be more “banked” (similar to race car tracks).

Next-Gen High-Speed Rail trains require roughly 5 minutes of acceleration over 16 miles of straight and flat track to achieve 200 mph. Next-Gen high-speed systems must provide alignment segments wherever possible that allow for these types of operating speeds if true high-speed travel time goals are to be met.



Comparison of Minimum Curve Radii: Next-Gen High-Speed Rail and 65-mph Commuter Alignments

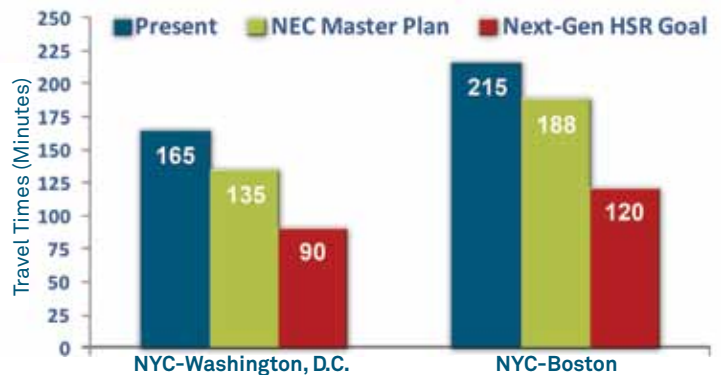

Travel Time Goals for New York City-to-Boston and New York City-to-Washington, D.C. Travel Markets

# 3.0 Next-Gen High-Speed Rail — Possible Alignments

The study team needed to develop a highly conceptual alignment with sufficient detail to allow capital costs, travel times, ridership and other factors to be estimated. The potential alignment goals were to:

- Provide service to key market areas and enable travel time goals to be met,
- Connect to local and regional train services,
- Be constructible and phased with existing NEC systems,
- Provide a separate two-track high-speed rail alignment, following existing corridors where possible,
- Limit impacts on existing development and sensitive areas (e.g. parks, wetlands, etc.), and
- Minimize capital costs where possible.

A number of possible alignments were initially analyzed for their potential to meet these goals.

## New York City to Boston

In the New York City-to-Boston segment, the study team examined a variety of potential alignments (see figure at bottom of page), including a “**Shore Alignment**” paralleling the existing NEC; a “**Long Island Alignment**” heading east of out New York and traversing Long Island Sound; and “**Highway**” alignments paralleling all or portions of major interstate highways, including I-84, I-90 and I-91, through Connecticut and Massachusetts. It is important to note that virtually all of the alignments considered pose a variety of construction and environmental challenges. It was beyond the scope of this study to analyze all potential alignments in significant detail. However, a representative alignment was chosen for analytical and costing purposes. This “**Analyzed Alignment**,” as shown in the figure, parallels the existing NEC from New York to just north of New Rochelle, then follows a combination of highway, rail and overland routes through Connecticut and Massachusetts, before rejoining the existing NEC south of Rt. 128 in Massachusetts and paralleling it into Boston. A route

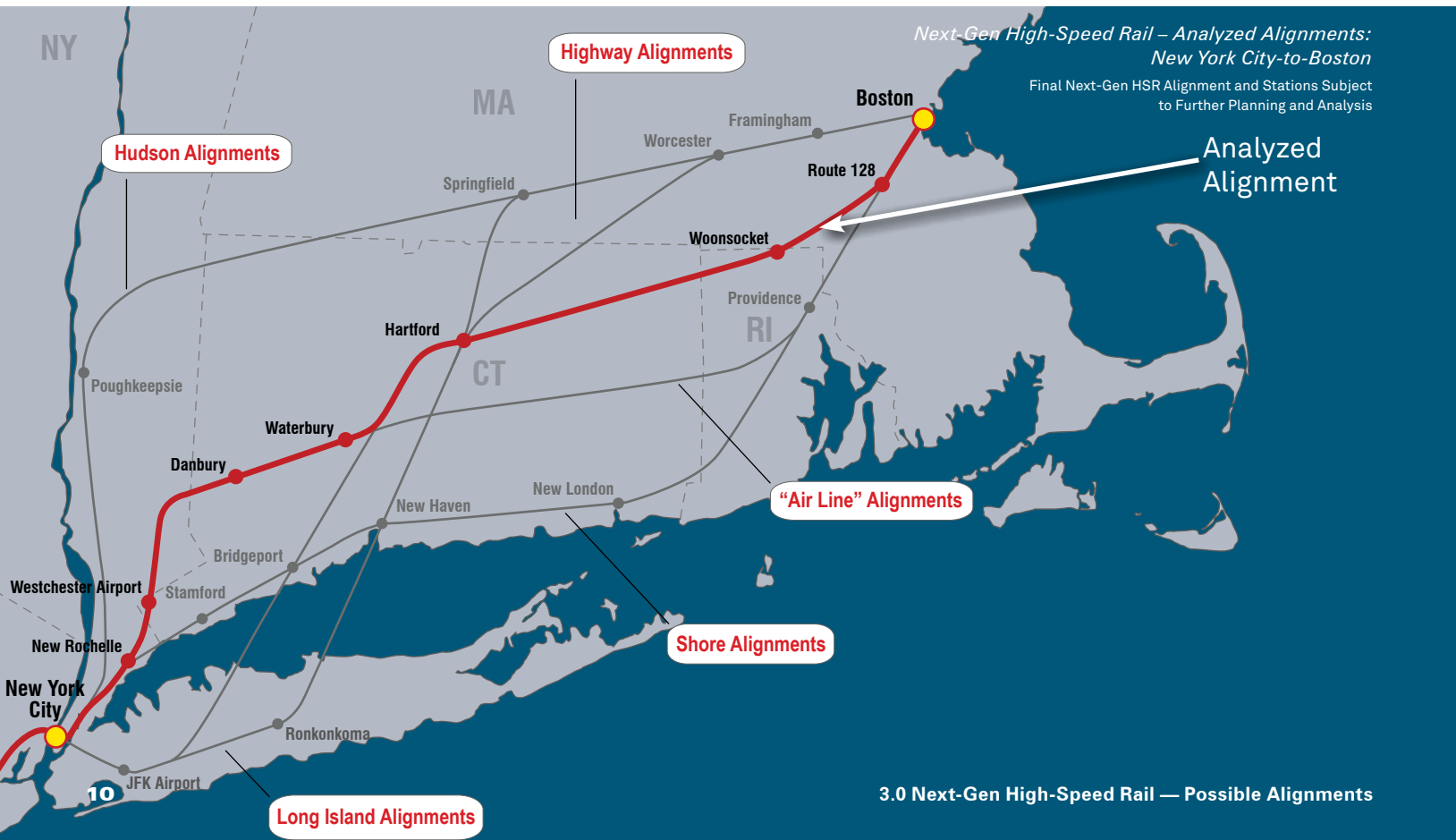



substantially paralleling the existing NEC between Boston and New York was not chosen for initial analytical purposes because of a combination of capacity constraints on Metro-North’s New Haven Line between New Haven and New Rochelle. Curvature restrictions and design requirements to meet environmental concerns on the Amtrak-owned “Shore Line” from the Massachusetts state line to New Haven would make it extremely difficult to meet the travel time targets of approximately one hour and 30 minute service.

### New York City to Washington, D.C.

For the New York City-to-Washington, D.C. segment, a similar process was followed. Potential alignments examined including an “Allegheny Alignments” through central New Jersey or eastern Pennsylvania, and “Inland” and “Shore” alignments that would swing east of the existing through largely suburban areas of Maryland, Delaware and New Jersey. These alignments would take advantage of existing

highway routes and less dense land development patterns for acquiring new rights-of-way, but would by-pass many of the major urban areas presently served by Amtrak along the NEC, such as Newark, Philadelphia, and Baltimore.

The “**Analyzed Alignment**,” shown in the figure below, is one that substantially parallels the existing NEC to continue serving the region’s major downtown areas, but deviates at key locations (e.g. Philadelphia and Baltimore) to straighten trackage that would potentially pose unacceptable speed constraints while still serving downtown locations, albeit at alternative downtown locations.

Whatever alignment is eventually selected for the NEC would be the result of considerably more detailed planning and engineering analyses, comprehensive stakeholder engagement efforts and detailed coordination with transportation and land use development plans along the corridor. While the alignment, station locations, travel time predictions,

Next-Gen High-Speed Rail – Analyzed Alignments: New York City-to-Washington, D.C.

Final Next-Gen HSR Alignment and Stations Subject to Further Planning and Analysis



and cost estimates coming from that process would vary from those presented here, the study team feels that the concept discussed further below provides a reasonable picture of the type of system that could meet the future high-speed rail needs of the Northeast.

### Potential Alignment Concept and Stations

The analyzed alignment would include two dedicated tracks protected by fencing, requiring new right of way (ROW) along most of its length, except where new ROW needs would be minimized by following existing highway and rail lines (predominantly along the existing NEC in its southern segment and along some highways in New York and Connecticut). It would include stations at the following locations:

Hub City Stations	Major City Stations	Other Stations	
Baltimore-BWI Airport	Hartford, CT	Rt. 128 (Westwood, MA)	New Rochelle, NY
New York Penn Sta.	Newark, NJ	Woonsocket, RI	Newark, NJ - Airport
New York GCT	Wilmington, DE	Waterbury, CT	Trenton, NJ (potential)
Philadelphia, PA	Baltimore, MD	Danbury, CT	Philadelphia Airport
Washington, D.C.		White Plains, NY- Airport	Baltimore (BWI) Airport

Roughly half of the 430-mile alignment would run parallel to existing rail lines or in urban rail or tunnel segments (including below-ground stations), with the other half located in new ROW or on bridges. Maintenance and storage facility concepts were also developed and sited at appropriate locations.

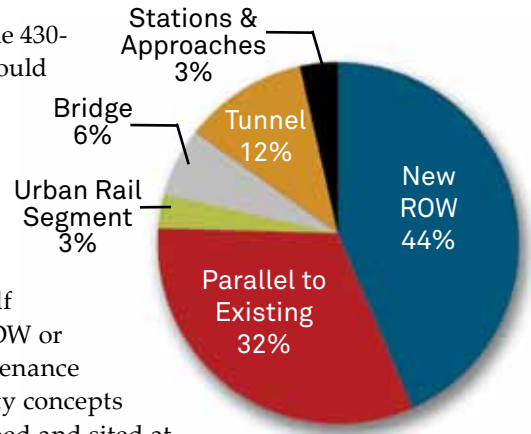

Hub City Stations would be located at **Union Station** in Washington, a new **Philadelphia Market East Station**, **Penn Station** and **Grand Central Terminal** in New York City, and a new terminal facility at **Boston South Station**. Other urban stations would be in central business district locations, at or next to existing stations, where possible, or at nearby areas that have good rail access and the potential for significant transit oriented development around the new facility. Direct links to airports would be provided where possible (Newark, Philadelphia, Baltimore, White Plains), with existing or potential future transit links to others (Boston, New York, Washington, D.C., etc.).

### Analyzed Next-Gen High-Speed Rail Alignment



## High-Speed Rail Connections to Local and Regional Rail Systems

The study team developed six different station locations which would link up with existing Regional and commuter rail services along the entire length of the corridor, from Amtrak Regional and MBTA commuter rail connections in Boston to Amtrak Regional and MARC/VRE commuter

service links in Washington, D.C. Similar extensive connections would be available in the other Hub cities of New York City and Philadelphia, strongly supported by major rail transit networks. With commuter rail and/or Amtrak connections at virtually every other planned station, the proposed alignment concept would have the ample transportation network connectivity that an effective Next-Gen High-Speed Rail corridor requires.

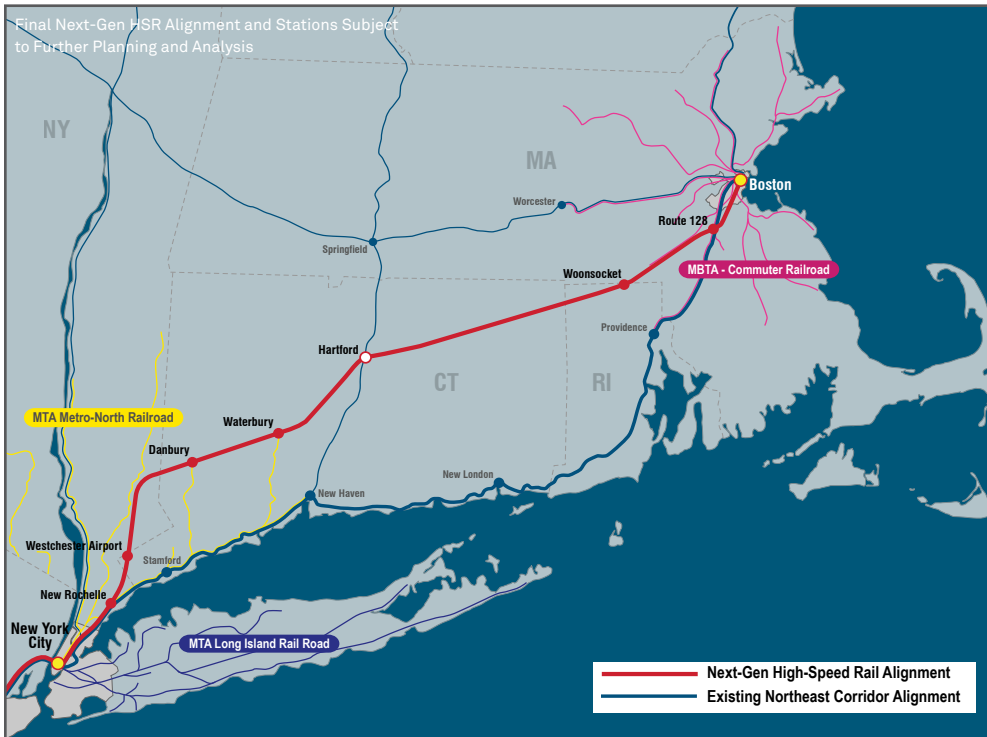

Connections to Regional and Commuter Rail Systems: New York City-to-Boston

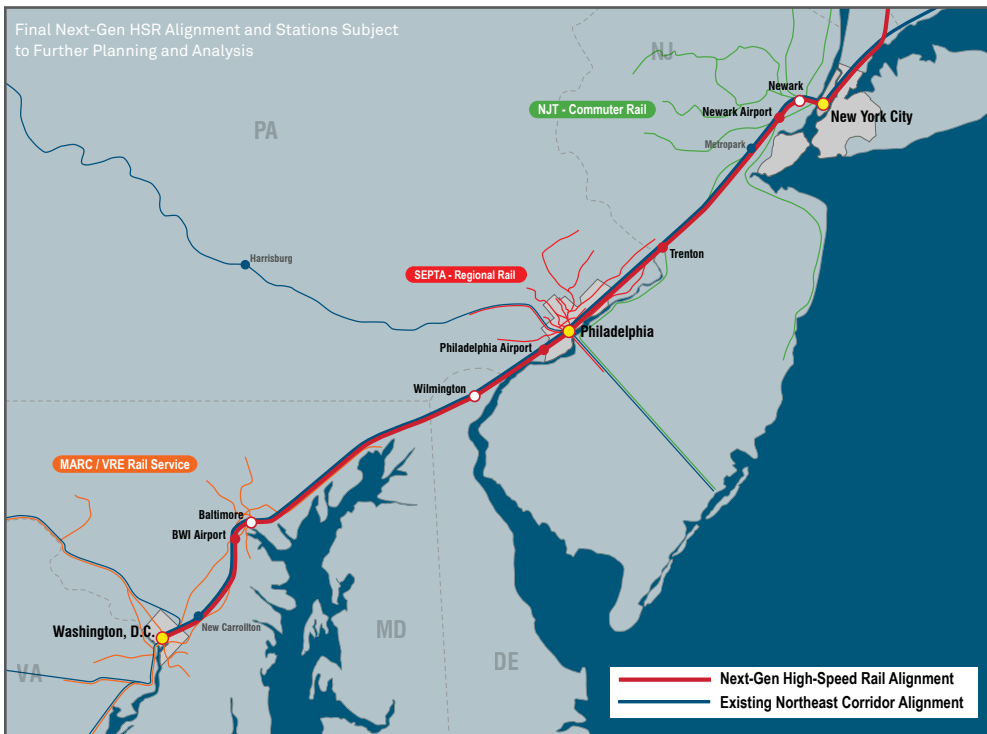

Connections to Regional and Commuter Rail Systems: New York City-to-Washington, D.C.

## Next-Gen High-Speed Rail — Stations

Modern high-speed rail stations around the world reflect the need for a high level of passenger convenience, comfort and safety, including direct and seamless links to connecting modes (other rail services, local transit, taxis, etc.) and pedestrian links to the surrounding urban context. Space for ancillary facilities for staff and supporting operations are also required. Vertical circulation systems (escalators and elevators) will provide a high level of service, even in peak travel periods. They will also meet important emergency egress requirements, and fully assist passengers with disabilities and those carrying baggage and children.

While all trains will stop at the Hub City Stations, some trains will be passing through other stations at speeds well below those reached between stations, but sufficiently high to minimize the impact on travel time. Station concepts were developed to understand space requirements and cost implications. These concepts were designed consistent with recently developed Next-Gen High-Speed Rail systems in Europe and elsewhere, to ensure passenger safety and comfort while maintaining efficient through-train operations.

A mixture of high-speed rail station concepts was developed to meet the proposed system’s needs:

*Concept Renderings of Possible Next-Gen High-Speed Rail Stations in the NEC.*

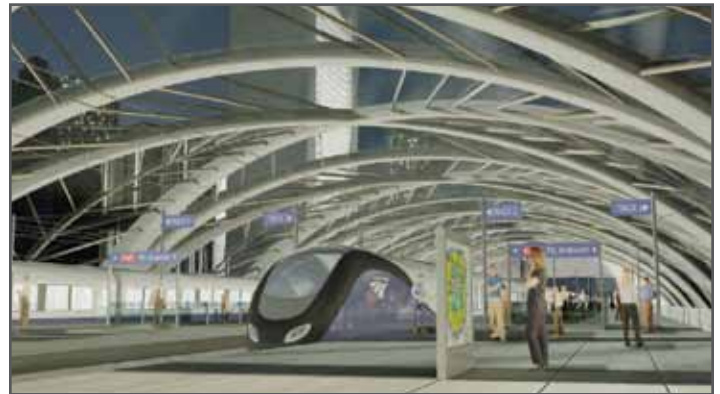



Station Category	Below-Grade	At-Grade	Elevated
Hub City	✓	✓	
Other Urban	✓	✓	✓
Suburban/Airport		✓	✓

part of an over 5-mile tunnel segment taking the high-speed rail alignment beneath the city. A 7.5-mile tunnel would similarly carry the alignment below the city and connect to an underground Hub City station at **Philadelphia Market East**. The two assumed New York City stations at **Penn Station** and **Grand Central Terminal** would also be underground and connected along an 11.8-mile tunnel segment – the system’s longest. A 6-track at-grade concept was assumed for the Hub station in **Boston**, based on the projected at-grade profile of the alignment in that area and the potential availability of land with convenient rail connections.

The Hub City Station concept provides for six tracks and platforms to handle the higher volume of trains, passengers and connections among services, while other stations would typically include four tracks and two platforms. Station concepts were assumed for each projected stop (for alignment and costing purposes) based on the station’s category and setting, taking into account the alignment’s profile in the station’s vicinity (in a tunnel, on a viaduct, etc.). For example, a new at-grade station near the existing NEC rail station was assumed at the **BWI Airport**, while the new **Baltimore Charles Center Station** would be underground,

The actual design for each station and its final location would be reviewed and refined under subsequent, more detailed planning and engineering studies. Of equal importance would be the coordinated planning for new development around these stations, as each city would use the High-Speed Rail system’s enhanced connection to regional, commuter and transit rail networks in the corridor to spur smart, sustainable growth.

*Elevated Suburban 4-Track Station*

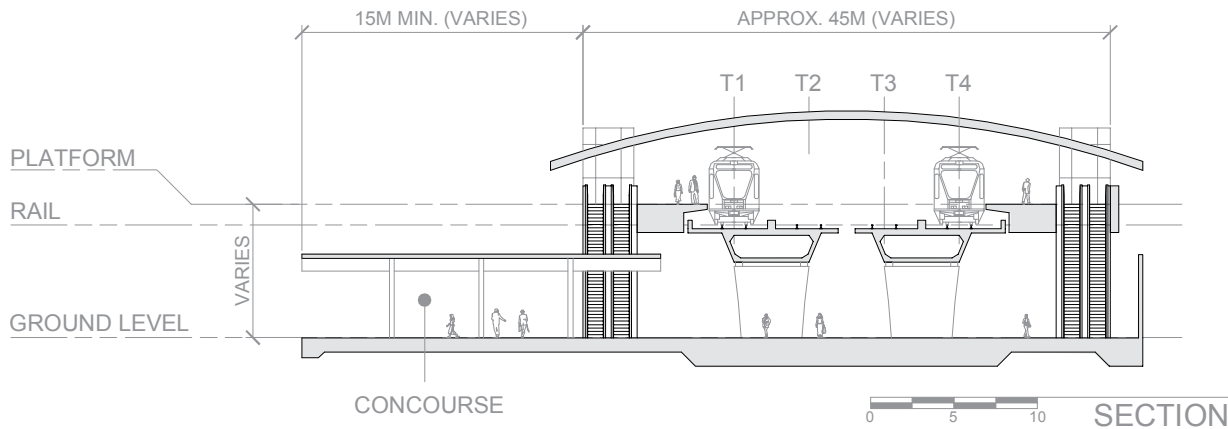

*Underground Hub City 6-Track Station*

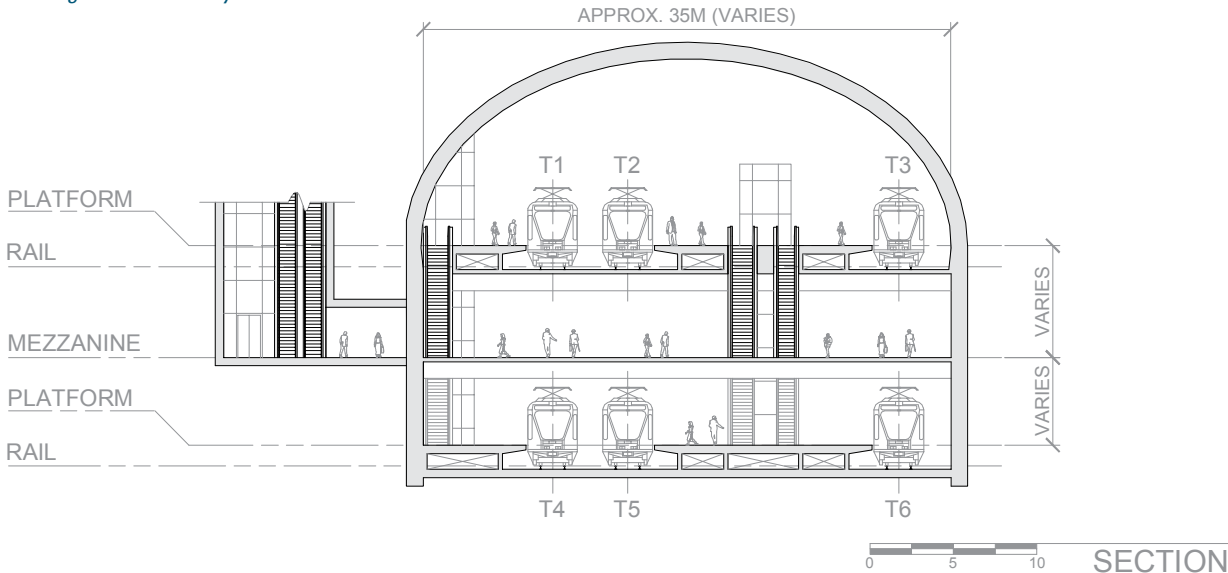

# 4.0 Service Plans, Rolling Stock and Travel Times

## Next-Gen High-Speed Rail — Service Plan

Along with conventional Regional Service on the NEC and the Keystone and Springfield Lines, four types of high-speed rail service would be provided:

- **Next-Gen High-Speed Rail Super Express** serving only the Hub Cities of Washington, D.C., Philadelphia, New York and Boston.
- **Next-Gen High-Speed Rail Express** serving the four Hub Cities and various combinations of other cities (e.g., Hartford) and intermodal station stops (e.g., Newark International Airport) on alternating trains (either Express A or Express B service).
- **Keystone Express** following the Keystone Corridor, then accessing the Next-Gen High-Speed Rail alignment north of Philadelphia to provide a high-speed rail ride from there to New York.
- **Shoreline Express** serving the southern end of the Next-Gen High-Speed Rail, but switching to the existing NEC near Newark Airport to serve Penn Station New York, Stamford, New Haven, Providence and Boston.

## Next-Gen High-Speed Rail — Vehicles and Operating Speeds

Several designs for high-speed rail vehicles presently in service around the world have the ability to meet the NEC's Next-Gen High-Speed Rail requirements. The performance, size, seating capacity and related information used in the study were based on train sets presently produced by Alstom (France) and Siemens (Germany). Federal regulations mandate that such materials and goods used in the project must be produced in the U.S., and domestic and international companies would likely develop U.S.-based plants to meet these requirements in the future.

The Next-Gen concept 400-passenger trains (8 coaches and 2 power cars, approximately 800 feet long) would have First and Business Class seating, a café car (possibly with table service), wi-fi and other customer amenities that today's travelers expect. They would have the top speed (220 mph) and other performance characteristics needed to meet travel time goals.

The analyzed alignment would allow Next-Gen High-Speed Rail trains to achieve up to 220 mph top design speed, but opportunities for sustained maximum speed operations are



limited due to the distances required to attain that speed; speed reductions imposed by variations in track curvature or grade; and, of course, the need to stop at intermediate stations to pick up and drop off passengers. Computer simulations of train operations, taking into account the geometry of the concept alignment and the performance capabilities of the trains, show wide variations in speed, but show average “commercial” operating speeds (which include time stopped at stations) comparable to or better than high-speed rail systems worldwide.

### Next-Gen High-Speed Rail — Travel Times

Simulations of Next-Gen High-Speed Rail train operations show that the 96-minute travel time for the Next-Gen Super Express between Washington, D.C., and New York would effectively meet the travel time goal of 90 minutes – a 40% reduction over Acela services. The New York-to-Boston time of 83 minutes (61% less than Acela) would substantially surpass the initial goal of 120 minutes. Equally important, the Boston-to-Washington travel time would effectively be cut in half, with over 3 hours cut from the current travel time. The significant travel time gains on the Next-Gen High-Speed Rail Express service demonstrate that for numerous intermediate markets presently serviced on the NEC (e.g., New York-

to-Baltimore, Boston-to-Philadelphia) the convenient and comfortable Next-Gen High-Speed Rail service would now be a compelling alternative to highway and air service modes. For example, Hartford-to-Philadelphia is now a 4-½ hour rail trip that is not competitive with air service. The Next-Gen High-Speed Rail Express service would quadruple the train frequency and take roughly 2 hours downtown-to-downtown, more than competitive with air service (1:20 travel time plus 2-plus hours of airport access and security clearance time).<sup>1</sup>

NEC Travel Times Between Hub Cities

	Washington - New York	New York - Boston	Boston - Washington
Acela	2:42	3:31	6:33
Next-Gen High-Speed Rail Express	1:55	1:46	4:06
Next-Gen High-Speed Rail Super Express	1:36	1:23	3:23*
Air Service**	3:05	3:08	3:28

\* Includes two stops in New York City.

\*\* Scheduled flight times plus 2 hours for trips between downtown and airport plus security clearance.

<sup>1</sup> Based on average time of US Airways schedules for weekday flights.

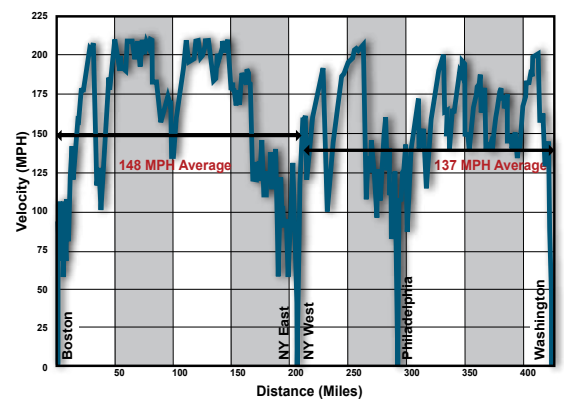

Simulated Velocity: High-Speed Rail Super Express



# 5.0 Ridership and Revenues

## Ridership under the NEC Master Plan

Amtrak operates premium high-speed (Acela) and regular (Regional/Keystone) service along the Boston-to-Washington, Springfield and Keystone Corridors, serving 11.8 million passengers annually. Amtrak’s travel demand model, developed for the NEC, predicts ridership rising with continued economic growth in the Northeast; 35% more riders are projected over the 2010-2020 period with another 33% projected over the 2020-2030 period. However, even with planned NEC Master Plan improvements, the NEC’s capacity would be exceeded by approximately 2030, limiting Amtrak’s ability to increase service, especially its Acela operations. With this constraint, despite continued increases in intercity travel demand, NEC ridership would grow by only 10% over the 2030-2040 period, less than one-third the rate in the previous two decades.

## Ridership under the Next-Gen High-Speed Rail Operations

Regular Regional Amtrak service along the NEC and the Springfield and Keystone Corridors would continue, with Acela service replaced by Next-Gen High-Speed Rail services (Super Express connecting the four Hub Cities and Express service

making alternating stops at intermediate stations). Keystone and Shoreline Express services would utilize portions of the Next-Gen High-Speed Rail alignment. Next-Gen High-Speed Rail’s huge reductions in travel time and increases in train frequencies and overall service quality made possible with the added high-speed track capacity would result in a 44% increase in NEC ridership over projected Master Plan levels by 2040.

Close to three-fourths of the new riders would be those who would otherwise travel by highway (47%) or air (23%), with the balance representing “induced” trips – e.g., travelers making trips along the NEC that they would otherwise not have made by any mode.

A review of the projected market share in the Boston-New York City-Washington, D.C. markets with the full Next-Gen High-Speed Rail system in place shows that:

- Even though the role of premium

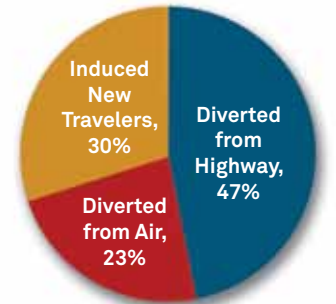

Source of New NEC Riders

Projected Ridership under the NEC Master Plan

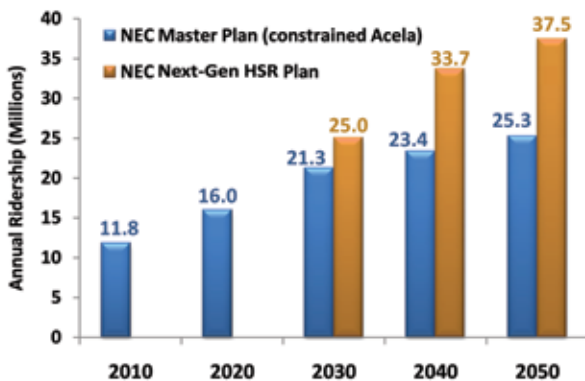

Projected Ridership by Service under NEC Next-Gen Plan

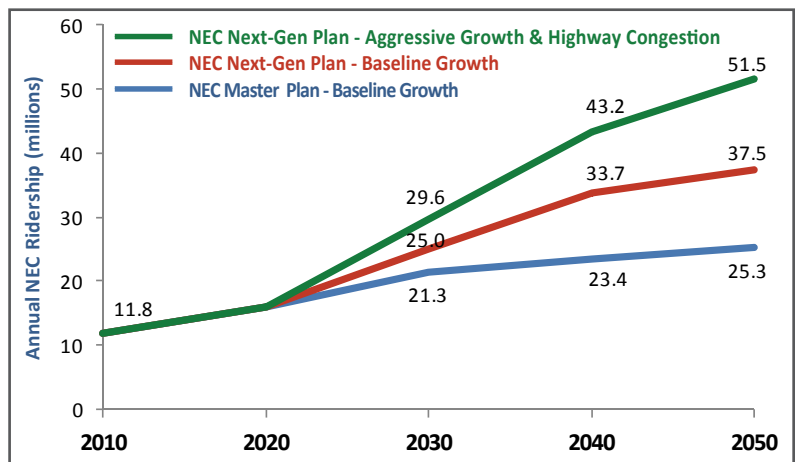
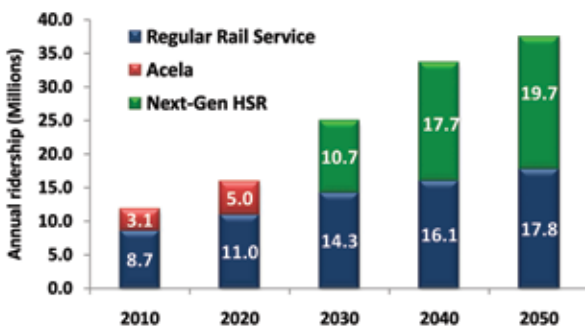



- service (with Next-Gen High-Speed Rail replacing Acela service) would double or triple, regular NEC services would still play an important role, and
- Auto and air modes would see a larger shift to rail, especially in the New York-Boston market, where the most dramatic improvement in rail travel times is predicted.

The overall 50% increase in ridership along the NEC spine would be driven by large increases in premium service ridership, especially by a three-fold rise in “North of New York” trips (starting or ending in New York, Boston, or points in between).

This 44% rise in overall NEC ridership would result in a 79% rise in passenger revenues (from \$1.84 billion to \$3.29 billion in 2010 dollars), reflecting the strong shift to the premium Next-Gen High-Speed Rail services (52% versus the 28% Acela share under the NEC Master Plan).

The projection of 33.7 million NEC riders in 2040 with the Next-Gen High-Speed System is based on relatively conservative demographic and economic projections for the NEC market areas by Moody’s Economy.Com. If that source’s more aggressive growth projections were utilized, and the worsened highway and airline congestion under that scenario were taken into account, projected NEC ridership would be over 43 million in 2040 and over 51 million by 2050.

Under NEC Master Plan projections, Acela riders would account for 28% of the 23.4 million total NEC riders in 2040. Next-Gen High-Speed Rail riders would account for over half (52%) of the 33.7 million riders under the Next-Gen High-Speed Rail Plan.

Annual NEC Ridership, 2040 (Millions)	NEC Master Plan			Next-Gen High-Speed Rail Plan		
	Acela	Regular	Total	Next-Gen HSR	Regular	Total
North of NYC	2.2	2.6	4.7	6.6	2.3	8.9
South of NYC	3.7	9.4	13.1	7.1	9.0	16.2
Through-NYC	0.6	1.5	2.2	3.4	1.5	4.9
<b>Sub-total: NEC Spine</b>	<b>6.5</b>	<b>13.5</b>	<b>20.0</b>	<b>17.1</b>	<b>12.9</b>	<b>30.0</b>
Keystone Corridor	0.0	2.1	2.1	0.5	2.0	2.5
Springfield Corridor	0.0	1.3	1.3	0.0	1.3	1.3
<b>Total Riders(Millions)</b>	<b>6.5</b>	<b>16.9</b>	<b>23.4</b>	<b>17.7</b>	<b>16.1</b>	<b>33.7</b>
<b>Annual Revenues - 2040 (Millions 2010\$)</b>	<b>\$0.89</b>	<b>\$0.95</b>	<b>\$1.84</b>	<b>\$2.39</b>	<b>\$0.90</b>	<b>\$3.29</b>

Distribution of New NEC Travel by Mode: 2010-2050

**NYC-Wash., D.C.**

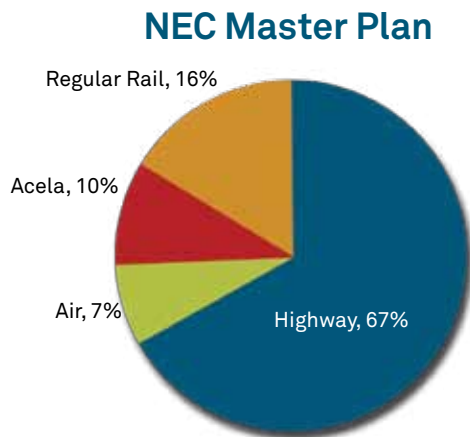

**Next-Gen NEC High-Speed Rail**

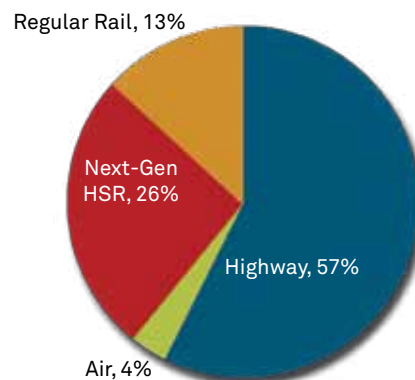

**NYC-Boston**

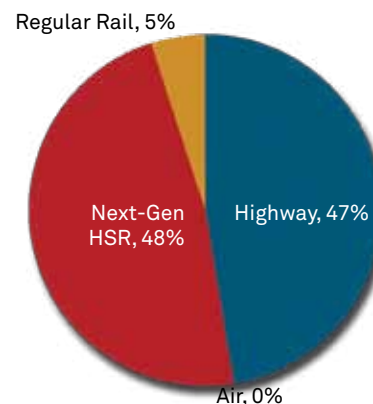
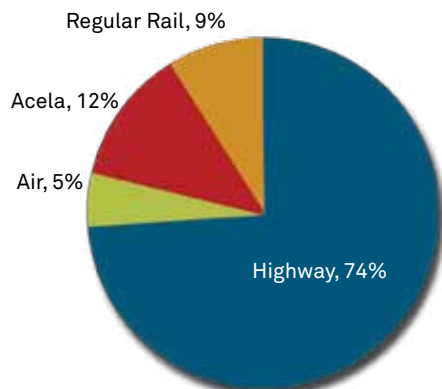

# 6.0 Capital and Operating and Maintenance Costs

## Capital Construction Costs

Capital costs for the Next-Gen High-Speed Rail system were established by breaking up the 427-mile analyzed alignment into 11 different segment types, such as tunnel section, elevated viaduct section, at-grade section, etc. Unit costs on a per-meter basis were then developed for each of these 11 sections, based on estimates for recent projects with similar overall section configuration and project complexity. These other projects included those in early planning and engineering stages and those in construction or recently completed. For those project cost elements primarily driven by route length – e.g., signals and traction power systems – a cost-per-kilometer approach was used based on recent representative projects. Other major system elements, like traction power stations or crossover “interlocking” locations, were folded into these per-kilometer figures.

Separate estimates were made for other significant project elements that would be needed, such as stations, long-span bridges, train storage yards, heavy repair and service and inspection facilities, etc. Costs for complex track connections, reconfiguration of existing track sections or interlocking

and similar system elements were also added. Then, real estate costs for required right-of-way were similarly estimated based on section type and location (rural, suburban, hub cities, etc.), and train equipment costs were estimated based on proposed service levels, travel times, back-up requirements, and so on.

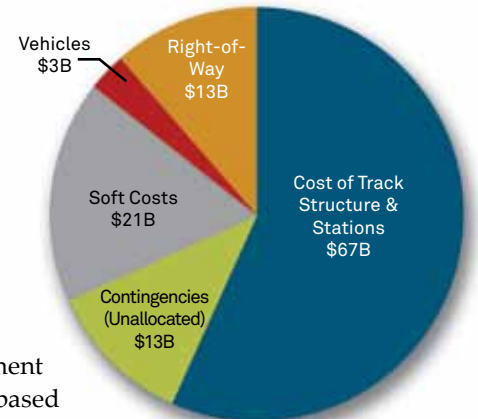

Projected Capital Construction Costs: \$117 Billion (\$2010)

Estimated costs were organized by Federal Transit Administration (FTA) cost categories, including extensive allocated cost contingencies to reflect the substantial amount of unknowns under this type of early concept study. Right of way, soft costs, and unallocated contingencies were also included. The projected construction costs (in 2010 dollars) for completion of the total system would be approximately \$117 billion.

Prototypical Segment Type (Cut-and-Cover Tunnel)

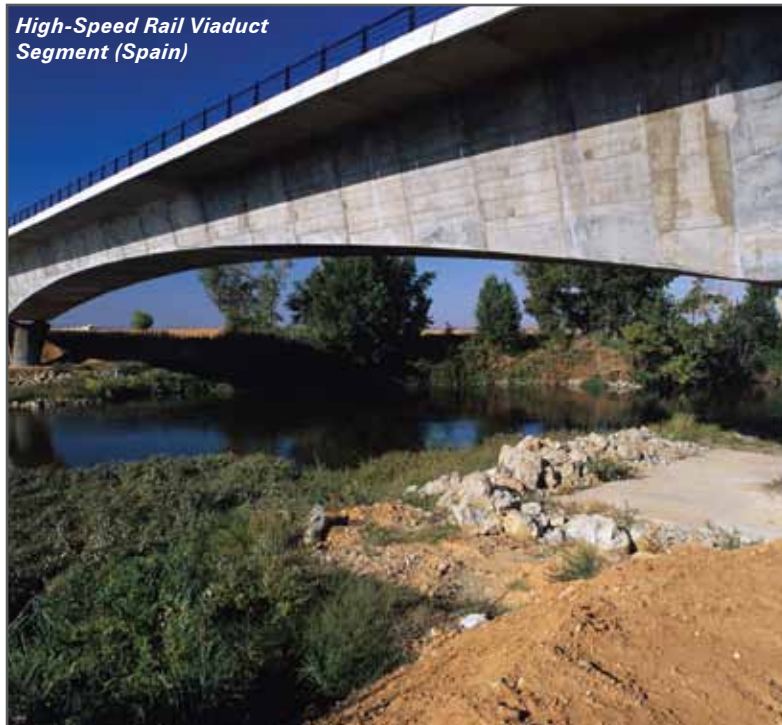
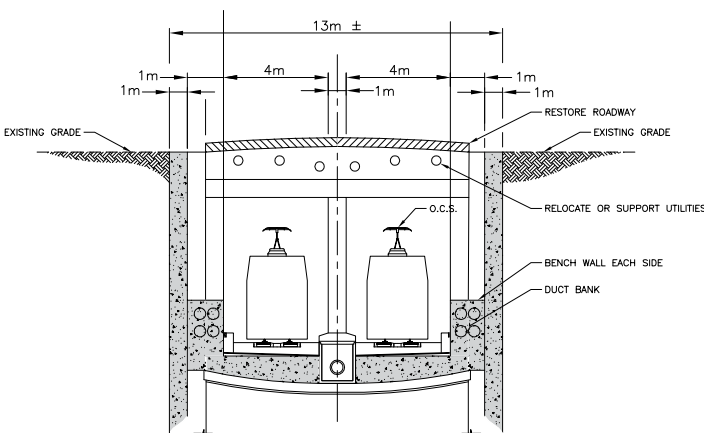

High-Speed Rail Viaduct Segment (Spain)

## Construction Phasing

The Next-Gen High-Speed Rail network envisioned in this study would be developed over an approximately 30-year period, from initial planning to completion of construction. The phasing would allow system improvements to be coordinated with other planned NEC upgrades, and for the gradual phase-in of Next-Gen High-Speed Rail service to merge efficiently to the rest of the NEC operations.

- Electric Traction Power to power the new trains.
- Equipment Maintenance – car turnaround services, etc.
- Station Services – ticketing, police, operations, etc.
- Sales and Marketing – reservations and information, marketing, national/corridor advertising, etc.

“Capital Renewal” costs would address more extensive maintenance-of-way and rolling stock overhaul during the life of the system.

## Operating and Maintenance Costs (O&M)

O&M costs for the Next-Gen High-Speed Rail services and infrastructure were developed in the following areas:

- **Train Operations** – train and yard operations, maintenance of way, electric traction power, etc.
- **On-Board Services** – food and supplies, on-board dining services, etc.
- **Maintenance of Way (MOW)** to maintain the tracks and related equipment.

Projected Annual O&M and Capital Renewal Costs (\$2010)

	Next-Gen HSR Express	Next-Gen Super Express	Keystone Express	Shoreline Express	Next-Gen Total Costs
Train Operations	\$74	\$34	\$9	\$40	\$156
On-Board Services	\$66	\$30	\$10	\$33	\$139
Maintenance-of-Way	\$59	\$29	\$9	\$26	\$122
Electric Traction Power	\$89	\$43	\$7	\$38	\$178
Equipment Maintenance	\$154	\$75	\$12	\$66	\$307
Station Services	\$79	\$38	\$11	\$33	\$161
Sales and Marketing	\$96	\$47	\$9	\$41	\$194
<b>Total Operating Expenses</b>	<b>\$616</b>	<b>\$296</b>	<b>\$67</b>	<b>\$278</b>	<b>\$1,275</b>
<b>Capital Renewal Costs (Maint. of Way and Rolling Stock)</b>	<b>\$172</b>	<b>\$84</b>	<b>\$19</b>	<b>\$74</b>	<b>\$349</b>
<b>Total Operating and Capital Renewal</b>	<b>\$788</b>	<b>\$380</b>	<b>\$86</b>	<b>\$352</b>	<b>\$1,605</b>

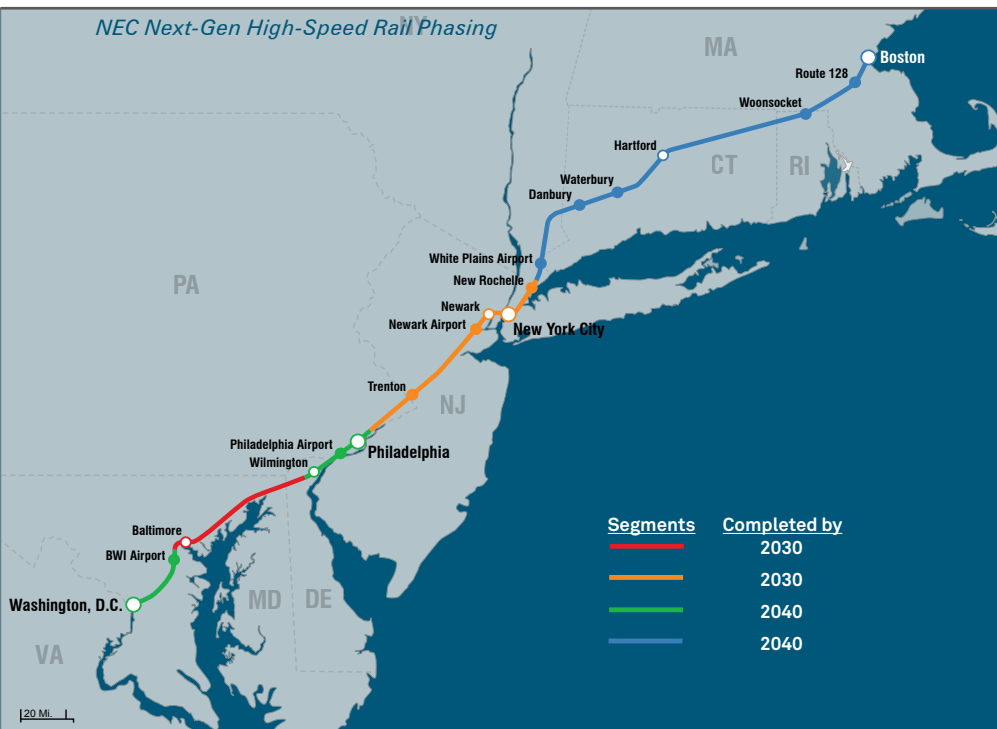



# 7.0 Financial, Economic and Other Benefits of Next-Gen High-Speed Rail in the NEC

## Financial Benefits

A critical benefit of the proposed Next-Gen High-Speed Rail service would be its ability to cover its overall operating and maintenance (O&M) costs (including long-term state-of-good-repair investments) and generate an annual operating surplus of approximately \$900 million. These funds would be available to support direct capital investment in equipment and other system components and/or leveraged along with potential private participation as part of a comprehensive Next-Gen High-Speed Rail capital investment plan.

## Economic Benefits

The proposed Next-Gen High-Speed Rail plan for the NEC would invest \$117 billion over the next 30 years, or approximately \$42 billion in 2010 dollars (at USDOT's discount rate of 7%). UNIFE (Association of the European Rail Industry) estimates that annual worldwide high-speed rail investments will increase to \$224 billion by 2016. The proposed NEC High-Speed Rail investment, while modest in a worldwide context, would be one of the nation's single largest public works projects, and requires careful review. At the same time, the health of the Northeast Corridor's economy is fundamental to that of the nation and the

strategic investments critical to its continued growth and competitiveness are of national importance.

The Gross Domestic Product (GDP) for the NEC corridor topped \$2.6 trillion in 2008, roughly 18% of the nation's economy, with New York and the other three high-speed rail "Hub Cities" accounting for 88% of the corridor total. The health of the corridor's economy is fundamental to that of the nation, due to its size and its linkages to national and international trade and commerce.

## Net Economic Value of the Project

Amtrak services must play an expanded role in meeting the corridor's mobility and economic support needs. The NEC's daily use by major commuter rail operations and by numerous freight trains further underscores this importance. The NEC Master Plan's projected repairs and upgrades will help maintain the corridor, but its capacity will be exceeded by 2030, putting serious constraints on Amtrak and other NEC-dependent operations and on the corridor's underlying economy. The benefits of the proposed Next-Gen High-Speed Rail system investment would extend beyond intercity rail passengers to air passengers, rail commuters, and highway drivers who will realize transportation network capacity gains.

Next-Gen High-Speed Rail Operations - 2040

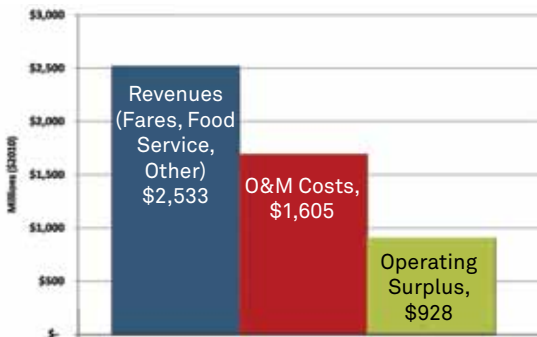

GDP (2008) by Metropolitan Area in Northeast Corridor (Billions of Current \$)

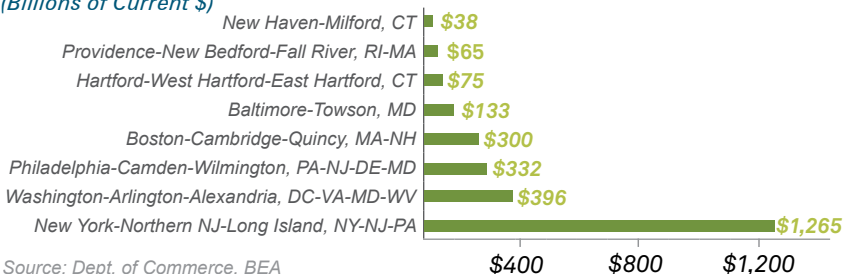

Source: Dept. of Commerce, BEA





Potential positive economic impacts of the proposed Next-Gen High-Speed Rail system would be generated in a number of areas (all dollar figures are in discounted 2010 dollars). The project's construction would directly increase employment and earnings along the corridor and beyond, with these workers' higher consumer expenditures generating more jobs to meet this increase in consumer demand. The project's construction would generate roughly 44,000 jobs annually and \$33 billion in wages over the 25-year construction cycle. Similarly, the Next-Gen High-Speed Rail system would support approximately 7,100 new permanent jobs within Amtrak, which along with indirect and induced employment result in a total of 22,100 jobs and \$1.4 billion in annual wages.

In addition to the project's construction cost, the following factors go into the project's formal benefit-cost assessment:

- **Residual Project Value** – The operation's costs would maintain the new system in a state of good repair. With a residual system value (beyond 2060) of approximately \$5.52 billion, the system would serve the corridor and region well into the late part of this century.
- **NEC Investment Savings** – Elements of the new high-speed rail system would eliminate the need for certain investments programmed under the Master Plan, valued at approximately \$6.33 billion.
- **User Benefits** – The new system would generate travel benefits for its users which have recurring economic value, as residents, business traveler and tourists travel more efficiently (travel time savings), safely (avoided accidents and fatalities), and with reduced vehicle operating costs, for a total of approximately \$5.0 billion.
- **Operating Surplus** – The new service's operating surplus over its initial 30 years of operation would generate a benefit of \$3.6 billion (based on leveraging these funds to support investments elsewhere in the system).
- **Reduced Energy Use and Emissions** – Based on U.S. EPA and DOE's evaluation factors, the reduction in travel-related emissions and energy consumption would be valued at approximately \$0.4 billion.
- **NEC Capacity and Travel System Gains** – Travelers' shift to high-speed rail would free up capacity and reduce delays on competing modes (on highways and especially at congested NEC airports), create roughly 126 new commuter rail service "slots" in key urban areas, with time savings for existing commuters by reducing delays (eliminating Acela-related conflicts), plus cost savings to new rail commuters. These factors add up to an overall value of \$15.1 billion.



High-Speed Rail Construction in Spain



- Market Productivity** – Better connections among the corridor’s high-value-added urban centers, access to a broader, diverse labor pool and client base and increased economic density around high-speed rail stations would enhance the productivity of the NEC economy, with convenient, high-speed connections facilitating face-to-face contact among specialized labor. The overall market value is conservatively estimated at \$7.34 billion over the analysis horizon, creating roughly 100,000 new jobs by 2040 and \$25 billion in wages over the 2025-2050 period.

*Projected GDP in Northeast Corridor (Billions \$2010)*

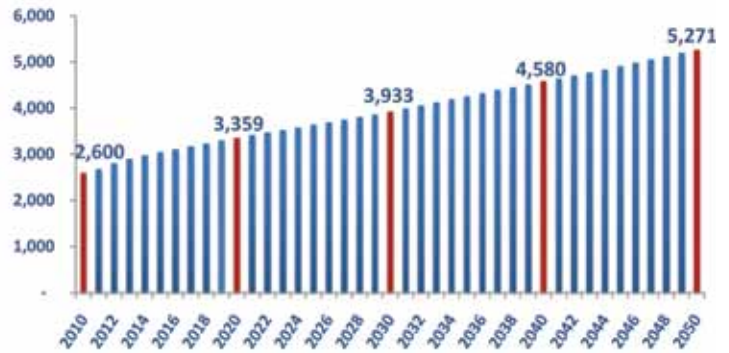

The Moody’s Economy.com economic projections for the Northeast Corridor represent unconstrained growth – i.e., they assume that necessary public and private investments (schools, sewage systems, transit systems, etc.) would be made to service the growing economy. The “baseline” growth for the Northeast Corridor reflected an annual GDP growth of approximately 1.78% over the 2010-2050 period. While the project’s \$117 billion cost is significant, in this economic context if the project succeeded in keeping even this mid-level growth rate from dropping by 0.05% it would have paid for itself. Given the documented need for this new high-speed mode, and its ability to enhance the way that the corridor’s urban areas would relate to each other, the future economic role of this vital investment will be far greater. The rapid development of similar high-speed rail projects in competing economic megaregions around the world further confirms this finding.

In summary, the NEC Next-Gen High-Speed Rail plan would provide a world-class rail system resulting in:

- 44,000 full-time jobs annually over the 25-year construction period;

## Summary of Financial & Economic Benefits of High-Speed Rail in the Northeast Corridor

Overall, the preliminary benefit-cost (B/C) assessment indicates that the proposed Next-Gen High-Speed Rail system would yield a positive B/C ratio of between 1.1 and 2.3, depending on the discount rate used. A B/C ratio of 1.1 – based on a 7% discount rate or “Opportunity Costs” recommended by the Office of Management and Budget (OMB) for major investment decisions – is very close to the 1.03 B/C ratio projected by the Federal Railroad Administration (FRA) for high-speed rail in the NEC in its 1997 “Commercial Feasibility Study.” Under a more realistic 3% discount rate reflective of opportunity costs in the current economic climate – one permitted by the U.S. DOT under its ongoing Transportation Investment Generating Economic Recovery (TIGER) grant program – the project has a benefit cost ratio of over 2.0. However, a B/C ratio cannot fully show the project’s significant economic impact on this vital economic engine – the NEC. Beyond the jobs associated with its construction and operation, it will change the structure and productivity of this region in ways that traditional economic models simply cannot capture.

*Summary of Benefit/Cost: National Perspective – Aggregate Net Present Value Using 3% and 7% Discount Rates*

	Total Value – 2010 to 2060 (Billions \$2010)	
	3%	7%
<b>Project Costs</b>		
Construction Costs	\$72.8	\$41.8
Credit for Residual Project Value	\$20.3	\$5.5
Credit for Avoidable NEC Master Plan Costs	\$8.3	\$6.3
<b>Net Project Costs</b>	<b>\$44.3</b>	<b>\$29.9</b>
<b>Project Benefits</b>		
Operating Surplus (Passenger Revenues – O&M Costs)	\$11.0	\$3.6
Travel Time & Cost Savings, Accident Avoidance, Highway Delay Reduction	\$16.3	\$5.0
Energy and Environmental Benefits	\$1.3	\$0.4
Commuter Network Benefits (Slots, New Commuters, Reduced Delays)	\$26.4	\$8.3
Air System Impacts (Reduced Air System/Traveler Delays)	\$21.5	\$6.8
Market Productivity Benefits	\$23.8	\$7.3
<b>Total Project Benefits</b>	<b>\$100.2</b>	<b>\$31.4</b>
<b>Benefit/Cost Ratio</b>	<b>2.26</b>	<b>1.05</b>

- 22,000 permanent jobs in the region due to expansion of Amtrak operations and spin-off secondary economic expansion;
- 100,000 additional permanent jobs due to increased regional connectivity, productivity and economic opportunities along the corridor;
- an approximate \$900 million annual surplus from Next-Gen High-Speed Rail operations;
- over \$6.3 billion reduction in other planned NEC investments;
- available NEC capacity for increased commuter operations with fewer delays and significant system and commuter benefits;
- reduced rail, auto and air network congestion and related user, environmental and energy benefits throughout the Northeast; and
- substantial reserve high-speed rail capacity to meet future corridor needs. The proposed service would run up to 5 trains per hour in each direction by 2040, utilizing only 25% of the system's maximum capacity of 20 trains per hour. Capacity would be available to meet annual ridership levels well above the 20 million projected by 2050 to serve the long-term needs of

a growing Northeast corridor, and to absorb trains from possible future high-speed rail tie-ins with other markets (e.g., Springfield, Albany, Richmond).

### Economic Value of Next-Gen High-Speed Rail in Context: Hartford, CT

Hartford, Connecticut, is a city facing economic challenges and seeking a role in the larger economy of the Northeast. Despite its concentration of insurance firms, corporate headquarters and government agencies, Hartford's employment declined 42% between 1970 and 1998 as jobs migrated to the suburbs and other metropolitan regions.

Hartford is strategically situated between New York City and Boston, but access to those key Hub Cities is hampered by often severe congestion. The rapid growth of those Connecticut cities with superior rail-based connections (e.g., Stamford) shows the benefit potential of such linkages. Hartford's current rail service is relatively infrequent and too slow to meaningfully compete with other modes for major market share.

Introduction of high-speed rail service to Hartford would provide travel times between Hartford and New York

Hartford's Union Station



Population and Jobs within 90 Minutes of Travel from Hartford

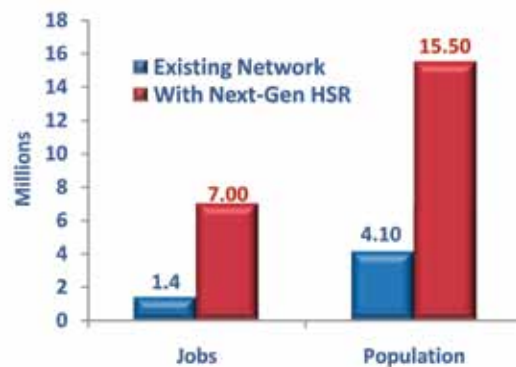

Existing NEC Service

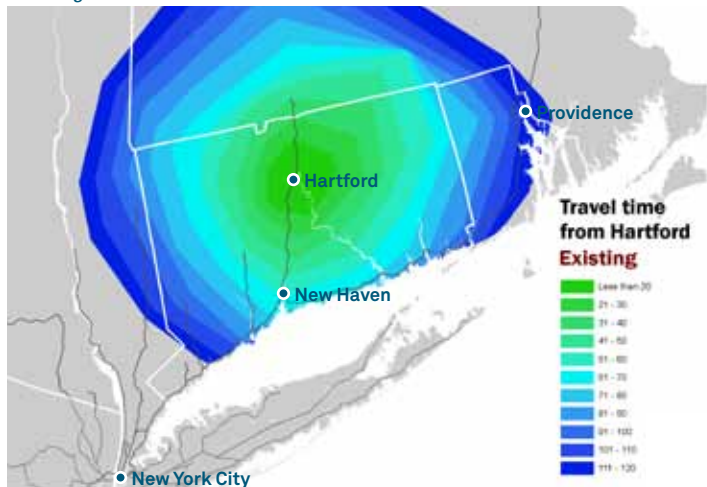

Proposed NEC Next-Gen High-Speed Rail Service

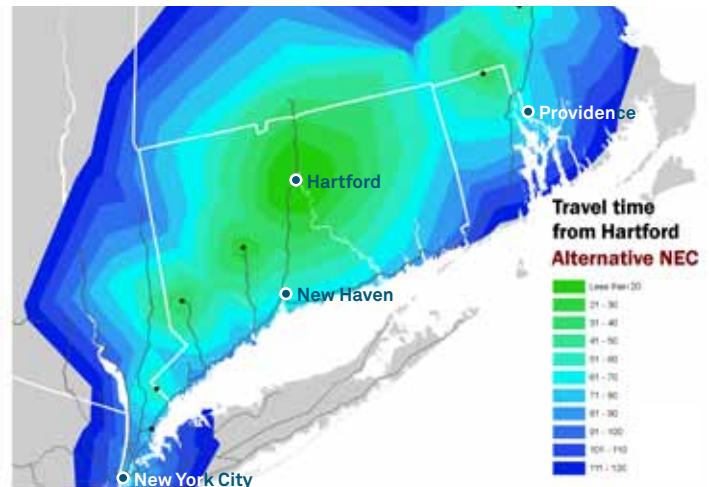



City almost comparable to what Stamford currently enjoys, with similar 1-hour access to downtown Boston. Expanding access to a larger workforce and more potential jobs via a rapid downtown-to-downtown connection would bring Hartford more tightly into the economic catchment areas of Boston and New York City. The population and jobs within 90 minutes travel of downtown Hartford would be 4 to 5 times higher with Next-Gen High-Speed Rail, compared to the present transportation network.

Hartford would experience a resurgence, with smart, sustainable growth replacing the parking lots and low-scale buildings presently surrounding Hartford's Union Station. The planned commuter rail system along the New Haven-Hartford-Springfield route would extend the high-speed rail service's benefits to the north and south, allowing West Hartford, Newington, Berlin and many other areas to evolve into more viable, sustainable and livable communities.

### Economic Value of Next-Gen High-Speed Rail in Context: Baltimore, MD

Despite strong regional growth trends in the 2000s fueled by the Washington and Baltimore metropolitan suburbs, Baltimore's growth was persistently weak. By bringing this new, vital rail mode into the core of the city's downtown, Next-Gen High-Speed Rail could provide the impetus necessary to refocus the region's growth into its primary city and bolster the state's economy. This action would be supportive of Maryland's groundbreaking programs to curb sprawl and revitalize the state's city and town centers.

The city of Baltimore has lost 300,000 residents (one-third of its population) since the 1950s, while the surrounding suburbs added one million. Presently, 90% of travel in

*Baltimore Regional Rail System Plan Map  
Adopted March 2002*

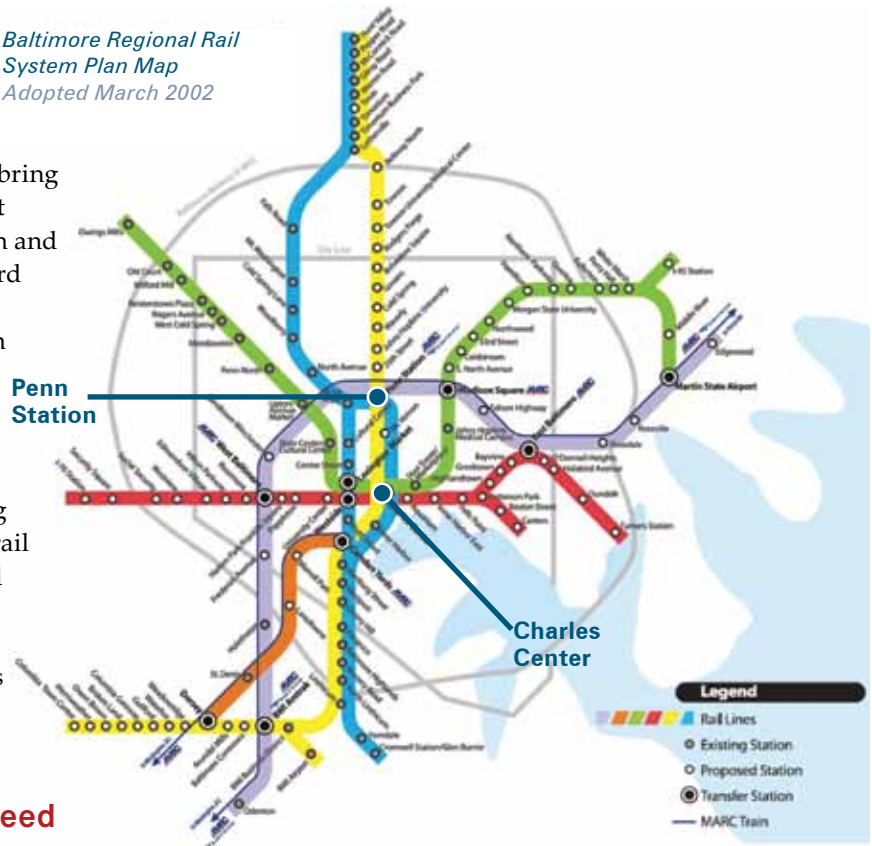

Baltimore County surrounding the city is in single occupancy automobiles, with peak period congestion rising sharply. Acknowledging this problem, recent transportation plans are focusing on road system preservation and transit expansion, with investments strategically coordinated with land use policy to support sustainable, transit-oriented growth. The Baltimore area's Regional Rail System Plan calls for over \$12 billion in transit investment to connect surrounding areas to downtown Baltimore, centered on the Charles Center and the nearby Inner Harbor.

While the existing Baltimore Penn Station provides some connectivity to regional and local transit services, its location is relatively removed from the city's commercial center. In



Charles Center Area



Baltimore Inner Harbor



contrast, the Next-Gen High-Speed Rail concept analyzed in this study would locate a new station beneath Charles Center, within convenient walking distance to the city’s major office buildings, sightseeing destinations and other amenities, with direct connections to the region’s transit network. These actions would more closely tie Baltimore to the economic engine of the Northeast Corridor, focusing growth around a revitalized and competitive urban core.

## Energy and Environmental Benefits

Intercity rail passenger operations accounts for 0.1% of the nation’s transportation energy consumption compared with 61% for light highway vehicles (cars, SUVs, small trucks). Domestic petroleum production roughly equaled transportation consumption in 1986, but by 2008 it could cover only half.<sup>2</sup> There are compelling economic, environmental and national security arguments for reducing petroleum consumption, and the transportation sector (70% of domestic energy use), is a critical policy target. Reductions in greenhouse gas emissions have a similar close tie to lowering transportation-related emissions.

Energy and environmental benefits cited in this study are preliminary and will be subject to further analysis and refinement in the next phase. The greatest energy savings and emission reductions would come from high-speed rail systems using electricity generated from renewal energy sources (as is being assumed for the California High-Speed Rail initiative). This study used publicly available data on existing energy use by highway and air modes, projections on future fuel economy trends from the Energy Information Administration, and Amtrak’s estimates of the present fuel mix used to generate the traction power for its existing NEC operations.

The key changes in NEC travel that would generate energy and environmental benefits were:

- the ability of the NEC to handle considerably more rail passengers than under the projected Master Plan levels, and
- the number of passengers that would divert from auto and air modes to NEC rail services.

U.S. Transportation Energy Use by Mode (2008)

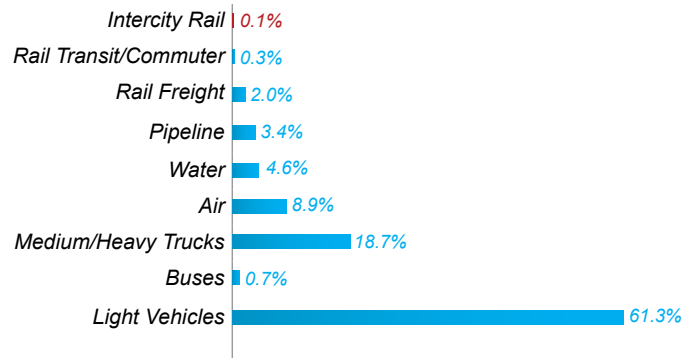

The value of energy saved is based on available data on fuel costs, while the monetary value of reductions in greenhouse gas emissions were taken from the Interagency Working Group on Social Costs of Carbon, U.S. Government in their February 2010 technical support document entitled “Social Costs of Carbon for Regulatory Impact Analysis.” These analyses indicate the following annual benefits at full buildout:

- 39 million gallons of gasoline saved,
- 7.3 million passengers diverted from auto and air modes, and
- 97,000 metric ton reduction in greenhouse gas emissions.

These are very preliminary estimates, which will be revisited and updated during more detailed analysis as the project advances.

<sup>2</sup> U.S. Department of Energy, Transportation Energy Data Book – 2010.

# 8.0 Next-Gen High-Speed Rail in the NEC – Summary and Next Steps

## High-Speed Rail is the Right Mode to Meet Growing Intercity Travel Demand

- Projected growth in the Northeast will substantially increase intercity travel demand, straining an already congested transportation network.
- Highway and air modes are already congested, their ability to expand is limited, and their continued expansion is inconsistent with national environmental and energy goals.
- Next-Gen High-Speed Rail in the NEC would provide increased intercity rail capacity but in a new, game-changing mode that would strengthen the vital NEC economy.

## The NEC is the Perfect Corridor for Next-Gen High-Speed Rail Service

- It is a large megaregion with major metropolitan areas separated by 100 to 400 miles, for which high-speed rail is optimally suited.
- Its complex and large economy (accounting for 18% of the nation's GDP) has the mix of high-productivity economic activities that would benefit from enhanced downtown-to-downtown connectivity.
- Its regional, commuter and transit rail services, feeding the corridor's major cities, provide the connectivity to support and expand the benefits of high-speed service.
- Amtrak, through its current generation of high-

speed Acela service, has experience with operating and attracting riders to high-speed rail.

## A NEC Next-Gen High-Speed Rail Corridor is Feasible, Competitive and Economically Viable

- Preliminary studies confirm that a dedicated high-speed rail alignment (approximately \$117 billion in construction costs), with highly-connected urban core stations is constructible and could meet very aggressive travel time goals.
- It would provide significant travel time savings and attractive premium service among Boston, New York, Philadelphia and Washington, D.C. and other cities, airports and suburban hubs. Its 96-minute service from New York-to-Washington D.C. and 83-minute New York-to-Boston service would generate high-speed rail ridership 5 times current Acela levels, and operate at an approximately \$900 million annual surplus.
- The NEC Next-Gen High-Speed network investment would have a positive Benefit/Cost (B/C) ratio of 1.1 under very conservative analysis assumptions and over 2.0 under assumptions better reflecting current estimates of opportunity costs.
- Its construction and operation would generate significant employment and economic activity along the corridor and elsewhere (all figures are in 2010 dollars):
  - o 44,000 average construction jobs annually over a 25-year construction period (1.1 billion person-years of construction work) with \$33 billion in wages,

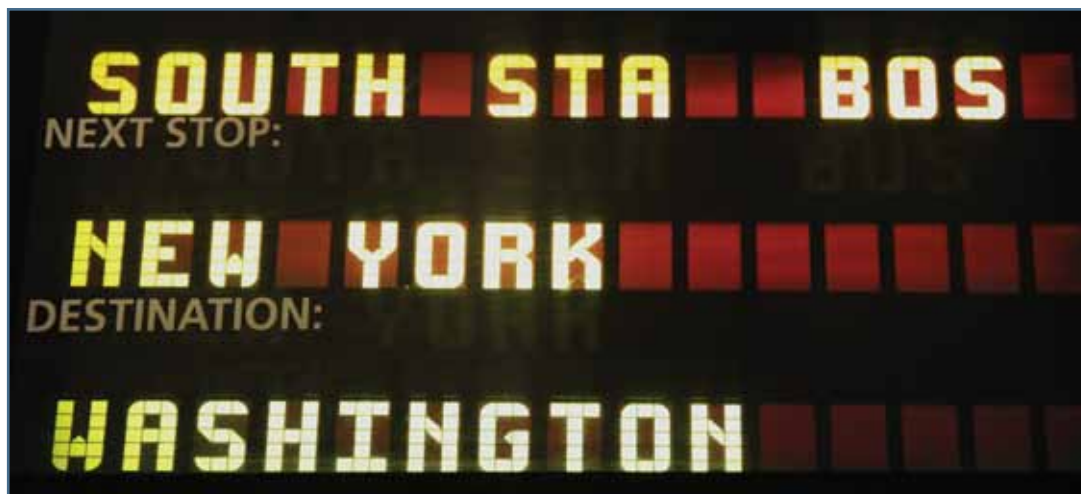

- o 22,100 permanent jobs with \$1.4 billion in annual wages due to the expansion of Amtrak’s operations, and
- o Over 100,000 new jobs in the corridor with \$25 billion in wages over the 2025-2050 period.

other concepts with different alignments would likely be further reviewed at that time.

The following are the likely next steps in the continued development of this concept:

- **Advanced Planning, Engineering and Environmental Studies** involving more detailed consideration of possible alternative alignments, station concepts, service plans, construction phasing and all other aspects associated with a project of this magnitude, along with completion of the associated environmental analyses and documentation.
- **Coordination with Other Corridor Land Use and Transportation Plans** to ensure that the eventually selected high-speed system is fully consistent with and supportive of local, regional and corridor-wide plans and policies.
- **Agency and Public Involvement Process**, especially during the planning and engineering study phases, to engage all interested public and private entities and the general public in the consideration of this important investment in the corridor’s future.
- **Funding Decisions and Preliminary and Final Design Process**, in which the financial mechanisms to develop this new system are established and the process of designing the system’s various components begins.
- **Project Construction and Operation**, with construction phased to coordinate with existing Amtrak and other rail operations in the NEC, and Next-Gen High-Speed rail service commenced as segments are completed.

### Next-Gen High-Speed Rail in the NEC – Next Steps

A Vision for High-Speed Rail in the Northeast Corridor marks an initial planning step that is projected to lead towards purposeful consideration and detailed planning for a timely, comprehensive and aggressively scheduled investment in high-speed rail in the corridor. The results of this study can be expected to generate further region-wide interest and discussion of this critical issue, as its findings are further vetted among stakeholders within the region including policymakers at the federal, states, and local level, Amtrak and other agencies as well as citizens nationwide.

As noted throughout this report, the specific high-speed alignment, station locations and concepts, maintenance yards, etc., that were analyzed in this study represent only one of a wide range of possible network and service configurations that could be developed. The analyzed concepts reflect the study’s underlying goals (aggressive travel time savings, station locations in downtown areas, etc.) and detailed preliminary planning and engineering assessments. These concepts can be expected to be subjected to revisions, refinements and changes under more detailed study, and





[www.Amtrak.com](http://www.Amtrak.com)

(See: Inside Amtrak, Reports and Documents)