

HEAD SOUTH
TO THE DELTA

2010

THE CONFERENCE OF THE YEAR

American Planning Association's
2010 National Planning Conference | New Orleans
Saturday, April 10–Tuesday, April 13

EVENTS



American Planning Association

Making Great Communities Happen



WHAT MAKES THIS THE CONFERENCE OF THE YEAR?

	Networking	Hundreds of sessions	
Top speakers	Planning is on the national agenda		Innovative ideas

Table of Contents

Website	3
Special Events	4
Featured Speakers	6
Training Workshops	7
Mobile Workshops	9
Sessions	14
Planning Expo	25
Registration & Housing Info	27
Meeting & Receptions	29
Tours	31

Acknowledgments

APA President

Bruce A. Knight, FAICP

AICP Commission President

Paul Inghram, AICP

Local Host Cochairs

Stephen D. Villavaso, FAICP

Yolanda W. Rodriguez

Timothy H. Jackson, AICP

APA

Chief Executive Officer

W. Paul Farmer, FAICP

APA

Chief Operating Officer

Charlotte McCaskill

APA's National Planning Conference is the premier educational event for planners the world over. No other conference offers the depth and breadth you'll find here. With hundreds of sessions, workshops, mobile workshops, and special events, you'll find just what you're looking for. And with thousands of planners and officials in attendance, you'll meet people who can help you solve the problems on your desk today and take your career to the next level tomorrow.

Planning is the key to the national agenda. New nationwide initiatives—from sustainability to neighborhood revitalization to high-speed rail—are shaping the planning agenda. Be prepared with the latest information.

For 2010 we've reorganized and shortened the conference to make it more convenient for you. You'll still find the wide variety of intensive, unparalleled educational opportunities that make the National Planning Conference the conference of the year.

We've shortened this preliminary program as part of our organization-wide efforts to be more environmentally conscious. Use this program as an overview to get a sense of what the conference will be about this year. Then head to www.planning.org.

You'll find a new and improved conference website, with full details on all the sessions, workshops, mobile workshops, and networking opportunities that make the conference great. If you like, put together your conference schedule. Or go straight to registration, which we've streamlined this year—again, in response to your requests.

Get all the details at www.planning.org

Full details on all conference activities

Search by keyword, activity number, name, event, topic, or speaker

Bookmark activities of interest and view as a list

Keep track of your conference information with a customized dashboard

Look for Helpful Itineraries

AICP member (how to get your 32 CM)

Student

New professional/early career planner

Mid-career planner

Planning director

Planning commissioner

AICP exam candidate

Transportation

Sustainability

Urban design

Law

GIS & technology

Community development and neighborhood

Small town and rural

Zoning codes

Economic development

Housing

When You Register

Know your APA ID and type. (APA members save big on conference registration)

Choose your registration option:

Value bundle (Saturday workshops plus the full conference, Sunday through Tuesday)

Conference only (Sunday through Tuesday)

Individual Saturday workshops

Add tickets to special events and mobile workshops (If you created a schedule, these will already appear on registration screen)

Finish up and pay

Keep working on your schedule or start a schedule even after you've registered

Front cover photo courtesy of the New Orleans Convention and Visitors Bureau/Richard Nowitz; page 2 and page 3 (right) New Orleans Convention and Visitors Bureau/Carl Purcell; page 3 (left) New Orleans Convention and Visitors Bureau; back cover photo courtesy New Orleans Convention and Visitors Bureau/Cheryl Gerber.



All photos this page courtesy of the New Orleans Convention and Visitors Bureau.

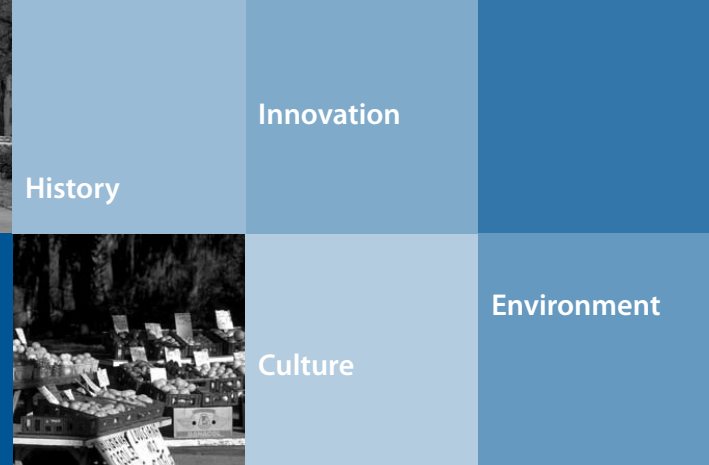

WHAT MAKES NEW ORLEANS THE PLACE TO BE IN 2010?

Come on down and find out!

A bustling neighborhood. An eye-opening streetcar ride. A front-porch conversation. It's the little things, the details, that make a place special. You'll find such little things in abundance in New Orleans, one of the great American cities.

As we complete our two-year journey from the headwaters of the Mississippi River to its delta, APA's National Planning Conference arrives in the Crescent City. Once there, we'll be taking a close look at what we can all learn about disaster recovery and climate change. And we'll examine the other lessons New Orleans holds for planners. The city will give us the opportunity to explore not only sustainability, but also plan making, historic preservation, tourism, and neighborhood planning.

New Orleans is a place where exciting ideas about green development are taking hold. New Orleans is a place where neighborhoods are finding new life. New Orleans is a place where you can see firsthand how planning matters. That's why, in 2010, New Orleans is the place to be.

Special Events

AICP Fellows Induction Ceremony and Reception (P001)

Saturday, 7:00–10:00 p.m.
Join the AICP College of Fellows as they welcome the 2010 class of distinguished members to their ranks. Selected AICP members who have made lasting contributions to the practice and profession of planning will be elevated to Fellow at this elegant event. The ceremony, held at the Hotel Monteleone, will be followed by a catered reception. Black tie optional. Registration required. The 2010 Fellows will receive a complimentary ticket for this event. Additional tickets may be purchased. No refunds or exchanges after March 11. **\$125**

AICP Community Planning Workshop (P350)

Saturday, 8:00 a.m.–4:30 p.m.
Help Ascension Parish identify priorities and create an implementation framework that could be the basis for a community benefits agreement to present a consistent message when negotiating with industry and the state. **\$65**
CM 12

Planning Commissioners and Appointed Officials Breakfast (P002)

Sunday, 6:45–8:00 a.m.
Join your colleagues for socializing and discussion. A hot buffet breakfast is served. Registration required. No refunds or exchanges after March 11. **\$44**

Planning Directors Breakfast (P003)

Sunday, 6:45–8:00 a.m.
Join your colleagues for socializing and discussion. A hot buffet breakfast is served. Registration required. No refunds or exchanges after March 11. **\$44**

Awards Luncheon (P004)

Monday, noon–2:00 p.m.
Enjoy lunch as APA and AICP present the 2010 National Awards for Planning, a multimedia celebration of the best projects, plans, and planners in the country. Awards honor planning landmarks and pioneers, citizens, and professionals who have achieved excellence and helped to improve the quality of life in numerous communities. One invitation is included with full registration. Additional tickets may be purchased for \$40.

APA/AICP Annual Meeting and Leadership Honors (X050)

Tuesday, 9:00–10:15 a.m.
Highlighting this year's annual meeting are addresses by APA President Bruce Knight, FAICP, and AICP President Paul Inghram, AICP, as well as announcement of the winners of the 2010 APA/AICP elections. The Leadership Honors ceremony features accomplishments of individuals and organizations receiving recognition in a number of areas.

Local Host Committee Special Events

American Routes Live! Dinner and Music Gala with Nick Spitzer (P100)

Sunday, 7:00–10:00 p.m.
Join Public Radio International host Nick Spitzer for an evening celebrating the musical heritage of New Orleans and southern Louisiana at the Sugar Mill, a restored Warehouse District landmark. Includes: Buffet dinner musical program. Cash bar. **\$75**

Mulate's Cajun Fais Do-Do (P101)

Sunday, 7:00–10:00 p.m.
Take part in the festivity of a true Cajun party—a Fais Do-Do—at Mulate's in the Warehouse District. Includes: Buffet dinner and live Cajun music. Cash bar. **\$50**

Riverboat Cruise (P102)

Monday, 7:00–9:30 p.m.
Cruise the mighty Mississippi River and enjoy an evening of fine dining and Dixieland jazz aboard the luxurious Steamboat Natchez. Includes: Buffet dinner, one drink ticket, live jazz band. **\$75**

FEATURED SPEAKERS

Policy makers and respected thinkers will come together in New Orleans to share their thoughts on the biggest issues of the day. This year, speakers will discuss the environment, infrastructure, housing, political and social issues, and global concerns.

Ambassador Renée Jones-Bos



Renée Jones-Bos became ambassador of the Netherlands to the United States in 2008. She also served in the Dutch Embassy in Prague as the deputy chief of mission (1994–98), as first secretary at the embassy in Washington, D.C. (1987–90), and at the embassies in Dhaka and Paramaribo (1982–87).

HUD Secretary Shaun Donovan



Shaun Donovan, the 15th Secretary for Housing and Urban Development, has a strong commitment to make quality housing possible for every American. *(Invited)*

EPA Administrator Lisa P. Jackson



Lisa P. Jackson is the first African American to serve as Administrator of the Environmental Protection Agency. Her priorities include reducing greenhouse gas emissions, improving air quality, managing chemical risks, cleaning up hazardous waste sites, and protecting America's water. *(Invited)*

UN-Habitat Executive Director Anna Tibajuka



Anna Tibajuka has been the executive director of UN-HABITAT since 2000. She was the special coordinator for Least Developed Countries, Landlocked and Small Island Developing Countries at the U.N. Conference on Trade and Development. *(Invited)*

Senator Mary Landrieu



Mary Landrieu became the first woman from Louisiana elected to a full term in the U.S. Senate in 1996. She has been the leading voice in Washington for the Gulf Coast recovery effort in the wake of hurricanes Katrina and Rita.

Photo Courtesy of New Orleans Convention and Visitors Bureau



BUILD SKILLS

TRAINING WORKSHOPS

New! All workshops are available as ticketed events. Choose from 21 half-day or full-day workshops or sign up for one of the two management institutes. Visit www.planning.org/conference for complete workshop descriptions including the skill level and intended audience; all offer interactive, lively, and in-depth training.

Management Institutes

New Directors Institute (W400) CM | 9

Saturday, 7:30 a.m.–5:30 p.m.
Includes: Lunch and refreshment breaks.
\$595; \$395 conference registrants

Managers Institute (W401) CM | 9

Saturday, 7:30 a.m.–5:30 p.m.
Includes: Lunch and refreshment breaks.
\$595; \$395 conference registrants

Training Workshops

Healthy, Appealing, and Walkable Communities (W402) CM | 8

Saturday, 8:00 a.m.–5:00 p.m.
\$295

Advanced Environmental Planning (W403) CM | 8

Saturday, 8:00 a.m.–5:00 p.m.
\$295

Climate Change Management and Sustainable Development (W404) CM | 8

Saturday, 8:00 a.m.–5:00 p.m.
\$295

Negotiation for Planners (W405) CM | 8

Saturday, 8:00 a.m.–5:00 p.m.
\$295

Advanced Transportation Planning (W406) CM | 8

Saturday, 8:00 a.m.–5:00 p.m.
\$295

Regulating First Amendment Land Uses (W407) CM | 4

Saturday, 8:00 a.m.–noon
\$150

Planning for a Disaster-Resistant Community (W408) CM | 4

Saturday, 8:00 a.m.–noon
\$150

Health Impact Assessment (W409) CM | 4

Saturday, 8:00 a.m.–noon
\$150

Imagining Better Communities (W410) CM | 4

Saturday, 8:00 a.m.–noon
\$150

Communicating through Social and Mass Media (W411) CM | 4

Saturday, 8:00 a.m.–noon
\$150

Preservation Disaster Preparedness and Recovery (W412) CM | 4

Saturday, 8:00 a.m.–noon
\$150

AICP Exam Prep (W413) CM | 4

Saturday, 8:00 a.m.–noon

A Leaders Tool for Advanced Leadership (W414)
CM | 4

Saturday, 8:00 a.m.–noon
\$150

Green Post-Disaster Redevelopment (W415)
CM | 4

Saturday, 1:00–5:00 p.m.
\$150
Sponsors: APA Hazards Planning Research Center and APA Green Communities Research Center

Charrettes and Social Media (W416)
CM | 4

Saturday, 1:00–5:00 p.m.
\$150

Placemaking and Form-Based Codes (W417)
CM | 4

Saturday, 1:00–5:00 p.m.
\$150

Developing Effective Climate Action Plans (W418)
CM | 4

Saturday, 1:00–5:00 p.m.
\$150

Graphic Design for Planners (W419)
CM | 4

Saturday, 1:00–5:00 p.m.
\$150

Affordable Home Ownership and Foreclosure (W420)
CM | 4

Saturday, 1:00–5:00 p.m.
\$150

Variances, Special Uses, and the Zoning Board of Adjustment (W421)

Saturday, 1:00–5:00 p.m.
\$150

Innovative Planning in Military Base Communities (W422)
CM | 4

Saturday, 1:00–5:00 p.m.
\$150

GIS Workshops

ESRI provides these ticketed workshops designed for planners. How is GIS technology evolving and how has planning benefited? Learn more about this key planning tool.

Introduction to GIS for Planners (W200)

Saturday, 8:00–9:30 a.m.
\$25

Using GIS for Site Selection (W201/W207)

CM | 1.5
Saturday, 10:00–11:30 a.m.

Monday, 8:00–9:30 a.m.
\$25

Empowering the Charrette through Web-Based GIS (W202/W209)

CM | 1.5
Saturday, 1:00–2:30 p.m.

Monday, 1:00–2:30 p.m.
\$25

Generating Effective Maps (W203)

CM | 1.5
Saturday, 3:00–4:30 p.m.
\$25

GIS and Delta Urbanism (W204/W210)

CM | 1.5
Sunday, 10:00–11:30 a.m.

Monday, 3:00–4:30 p.m.
\$25

Effective Zoning Management with GIS (W205)

CM | 1.5
Sunday, 1:00–2:30 p.m.
\$25

Practical 3-D Analysis and Visualization (W206/W208)

CM | 1.5
Sunday, 3:00–4:30 p.m.

Monday, 10:00–11:30 a.m.
\$25

Earn all 32 CM credits



Photo Courtesy of the New Orleans Convention and Visitors Bureau

VENTURE OUT

MOBILE WORKSHOPS AND TOURS

Venture out and see what makes New Orleans unique. Mobile Workshops offer the chance to see planning in action. Find out how New Orleans is focusing efforts on Gulf Coast recovery. Learn how communities worked together quickly to develop a post-Katrina master plan. Explore the intricate system of flood walls, pumping stations, gates, and levees keeping New Orleans dry. Get an introduction to the whole city with an orientation tour, or take part in a service project and make an impact on the New Orleans Community.

Many mobile workshops are biking, canoeing, running, or walking tours. They are a great way to see some of the best spots in New Orleans while getting a little exercise. Please be sure to bring appropriate clothing for your selected workshop.

APA Mobile Workshops will operate rain or shine. In the case of inclement weather, APA may alter a mobile workshop to ensure the safety of participants.

SUNDAY, APRIL 11

French Quarter Run (W003)
CM | 1

Sunday, 7:00–9:00 a.m.
Transportation: Running (five miles). **\$30**

Reinventing New Orleans Transportation (W004)
CM | 3

Sunday, 7:30–11:00 a.m.
Transportation: Bicycle. **\$55**

Housing Recovery and Sustainability (W005)
CM | 3

Sunday, 7:30–10:45 a.m.
Transportation: Bicycle (10 miles). **\$55**

Destination Downtown (W006)
CM | 2.5

Sunday, 7:30–10:30 a.m.
Transportation: Public, bicycle (five miles). **\$55**

Preserving LaBranche Wetlands (W007)
CM | 2

Sunday, 10:30 a.m.–4:30 p.m.
Transportation: Motorcoach, walking. Includes lunch. **\$100**

New Orleans Public Belt Railroad (W008)
CM | 4

Sunday, 10:30 a.m.–3:00 p.m.
Transportation: Motorcoach, walking. Includes lunch. **\$75**

Making New Orleans Resilient (W009)
CM | 2.5

Sunday, 10:30 a.m.–1:30 p.m.
Transportation: Motorcoach, walking. Includes lunch. **\$65**

Mississippi Gulf Coast Recovery (W010)
CM | 5.5

Sunday, 10:45 a.m.–4:45 p.m.
Transportation: Motorcoach, walking. Includes lunch. **\$75**

Transportation, Race, and Urban Design on I-10 (W011)
CM | 2.5

Sunday, 10:45 a.m.–1:45 p.m.
Transportation: Motorcoach, walking. Includes lunch. **\$65**



© Terria

Orientation Tours and Service Projects

New Orleans Orientation Tour

New Orleans: Risk, Recovery, and Resilience \$49

CM | 2

Saturday, 9:00 a.m.–noon (P300)

Saturday, 1:30–4:30 p.m. (P301)

Sunday, 9:00 a.m.–noon (P302)

Sunday, 1:30–4:30 p.m. (P303)

New this year! Additional Service Projects

Spend some time during the conference giving back to the New Orleans community. Select from one of three service projects, and prepare to get a bit messy while you make a difference!

Bayou Rebirth Service Project (W001)

CM | 1.25

Saturday, 8:00 a.m.–2:00 p.m.

Transportation: Motorcoach, walking. Includes lunch. **\$45**

City Park Service Project (W002)

Saturday, 8:00–11:30 a.m.

Transportation: Motorcoach, walking. **\$30**

AICP Community Planning Workshop (P350)

CM | 2

Saturday, 8:00 a.m.–4:30 p.m.

See page 4 for more details. **\$65**

SUNDAY, APRIL 11

Lafitte's Barataria Preserve (W012)

CM | 3

Sunday, 11:00 a.m.–2:30 p.m.

Transportation: Motorcoach, walking. Includes lunch. **\$75**

Planning for Suburbia Within the City (W013)

CM | 2.5

Sunday, 11:00 a.m.–2:00 p.m.

Transportation: Motorcoach, walking. Includes lunch. **\$55**

Born on the Bayou (W014)

CM | 3.5

Sunday, 11:15 a.m.–3:15 p.m.

Transportation: Motorcoach, canoe. Includes lunch. **\$95**

Post-Katrina Master Plan (W015)

CM | 2.5

Sunday, 11:15 a.m.–2:15 p.m.

Transportation: Motorcoach, walking. Includes lunch. **\$65**

Bienvenidos a New Orleans: Latinos & Planning Workshop (W016)

CM | 2.5

Sunday, 11:30 a.m.–3:30 p.m.

Transportation: Motorcoach, walking. Includes lunch. **\$50**

Recovering City Park from Katrina (W017)

CM | 2

Sunday, 11:30 a.m.–2:00 p.m.

Transportation: Motorcoach, walking. Includes lunch. **\$55**

Whitney Plantation (W018)

Sunday, 11:45 a.m.–3:45 p.m.

Transportation: Motorcoach, walking. Includes lunch. **\$70**

New Orleans's Mixed Use Neighborhoods (W019)

CM | 2

Sunday, 11:45 a.m.–2:15 p.m.

Transportation: Motorcoach. Includes lunch. **\$55**

Big Bicycle Plans and Neighborhood Recovery (W020)

CM | 5

Sunday, 12:45–5:15 p.m.

Transportation: Motorcoach, bicycle (8.5 miles). **\$75**

Bayou Sauvage by Canoe (W021)

CM | 2

Sunday, 12:45–4:45 p.m.

Transportation: Motorcoach, canoe. **\$95**

Strategies for Target Area Recovery (W022)

CM | 3.5

Sunday, 1:00–5:00 p.m.

Transportation: Motorcoach, walking. **\$60**

The LGBT Role in New Orleans Planning (W023)

CM | 2.5

Sunday, 1:00–4:00 p.m.

Transportation: Walking. **\$25**

Jane's Walk (W024)

CM | 1.5

Sunday, 1:00–3:00 p.m.

Transportation: Motorcoach, walking. **\$65**

Lafitte Corridor Greenway and Revitalization Project (W025)

CM | 2.5

Sunday, 1:15–4:15 p.m.

Transportation: Bicycle (seven miles). **\$55**

Artistic Urban Landscapes (W026)

CM | 2.5

Sunday, 1:15–4:15 p.m.

Transportation: Motorcoach, walking. **\$70**

Place Branding and the Arts (W027)

CM | 2.5

Sunday, 1:45–4:45 p.m.

Transportation: Public, walking. **\$35**

Managing Water with Blueways (W028)

CM | 2.5

Sunday, 1:45–4:45 p.m.

Transportation: Motorcoach, walking. **\$55**

Reinventing the Riverfront (W029)

CM | 2.5

Sunday, 1:45–4:45 p.m.

Transportation: Walking. **\$35**

Ninth Ward Hurricane Recovery and Revival (W030)

CM | 2.5

Sunday, 2:00–5:00 p.m.

Transportation: Motorcoach, walking. **\$55**

Planning Gives Life to Faubourg Marigny (W031)

CM | 3

Sunday, 2:00–5:00 p.m.

Transportation: Motorcoach, walking. **\$60**

MONDAY, APRIL 12

Faubourgh Marigny Run (W032)

CM | 1

Monday, 7:00–9:00 a.m.

Transportation: Running (five miles). **\$30**

Plan Baton Rouge, Phase II (W033)

CM | 7.5

Monday, 7:30 a.m.–3:30 p.m.

Transportation: Motorcoach, walking. Includes lunch. **\$95**

Life, Death, and Rebirth of Louisiana's Coast (W034)

CM | 7.5

Monday, 7:30 a.m.–3:30 p.m.

Transportation: Motorcoach, walking. Includes lunch. **\$95**

Post-Katrina Public Transit Challenges (W035)

CM | 3

Monday, 7:45–11:15 a.m.

Transportation: Public, walking. **\$40**

Small-Scale Greening, Large Neighborhood Impact (W036)

CM | 2.5

Monday, 7:45–10:45 a.m.

Transportation: Bicycle (15 miles). **\$55**

Coastal Erosion and Bayou Sauvage (W037)

CM | 3

Monday, 8:00 a.m.–noon

Transportation: Motorcoach, walking. **\$60**

Conflicting Rural Land Uses (W038)

CM | 3.5

Monday, 8:00 a.m.–noon

Transportation: Motorcoach, walking. **\$80**

From Micropolitan City to Regional Hub (W039)

CM | 4.5

Monday, 8:15 a.m.–1:15 p.m.

Transportation: Motorcoach, walking. Includes lunch. **\$75**

Senior Housing in the Ninth Ward (W040)

CM | 2.5

Monday, 8:15 a.m.–1:15 p.m.

Transportation: Motorcoach, walking. Includes lunch. **\$65**

Rebuilding Together New Orleans (W041)

CM | 3.5

Monday, 8:15 a.m.–12:15 p.m.

Transportation: Motorcoach, walking. **\$60**

Post-Katrina Economic Recovery in Slidell (W042)

CM | 4.5

Monday, 8:30 a.m.–1:30 p.m.

Transportation: Motorcoach, walking. Includes lunch. **\$95**

Hollygrove Livable Communities Project (W044)

CM | 2.5

Monday, 8:30–11:30 a.m.

Transportation: Motorcoach, walking. **\$55**

MONDAY, APRIL 12

**Historic Covington
Downtown and Trailhead
(W045)**
CM | 3.5

Monday, 8:45 a.m.–12:45 p.m.
Transportation: Motorcoach,
walking. **\$70**

Mississippi Riverfront (W046)
CM | 3

Monday, 8:45 a.m.–12:15 p.m.
Transportation: Public, walking.
\$35

**New Orleans MedZone
(W047)**
CM | 2

Monday, 8:45–11:15 a.m.
Transportation: Motorcoach,
walking. **\$65**

**Wolf River Conservation
by Canoe (W048)**
CM | 5.5

Monday, 9:00 a.m.–3:00 p.m.
Transportation: Motorcoach,
canoe. Includes lunch. **\$115**

**Neighborhood Recovery
in Lakeview (W049)**
CM | 3

Monday, 9:00 a.m.–12:30 p.m.
Transportation: Motorcoach,
walking. **\$60**

**The World's Fair's Legacy
(W050)**
CM | 2

Monday, 9:00–11:30 a.m.
Transportation: Walking. **\$25**

**Lafitte's Barataria
Preserve by Canoe (W051)**
CM | 3

Monday, 9:15 a.m.–2:45 p.m.
Transportation: Motorcoach,
canoe. Includes lunch. **\$95**

**New Orleans Jazz National
Historical Park (W052)**
CM | 3.5

Monday, 9:15 a.m.–12:45 p.m.
Transportation: Motorcoach,
walking. **\$60**

**Public-Private Revitalization
in Houma (W053)**
CM | 3.5

Monday, 9:30 a.m.–3:00 p.m.
Transportation: Motorcoach,
walking. Includes lunch. **\$95**

**Evolution of
Old Mandeville (W054)**
CM | 3.5

Monday, 9:30 a.m.–1:30 p.m.
Transportation: Motorcoach,
walking. Includes lunch. **\$85**

**New Orleans Streetcars
(W055)**
CM | 2.5

Monday, 1:00–5:30 p.m.
Transportation: Public, walking.
\$60

Bohemian Bywater (W056)
CM | 2.5

Monday, 1:00–4:00 p.m.
Transportation: Motorcoach,
walking. **\$55**

**Brownfields Redevelopment
as a Housing Solution (W057)**
CM | 3.5

Monday, 1:15–5:15 p.m.
Transportation: Motorcoach,
walking. **\$60**

**Growing Productive
Infrastructure Networks
(W058)**
CM | 3.5

Monday, 1:15–5:15 p.m.
Transportation: Motorcoach,
walking. **\$60**

**Flood Protection Choices
in New Orleans (W059)**
CM | 3

Monday, 1:30–5:00 p.m.
Transportation: Motorcoach,
walking. **\$60**

**Community Resilience in a
Post-Katrina Era (W060)**
CM | 3

Monday, 2:00–5:30 p.m.
Transportation: Motorcoach,
walking. **\$75**

**Housing Choices in a
Recovering Community
(W061)**
CM | 3

Monday, 2:00–5:30 p.m.
Transportation: Motorcoach,
walking. **\$60**

Port of New Orleans (W062)
CM | 1.5

Monday, 2:00–4:00 p.m.
Transportation: Boat. **\$70**

**French Quarter Retail
Foot Traffic (W063)**
CM | 2.75

Monday, 2:15–5:30 p.m.
Transportation: Walking. **\$25**

**Rebuilding, Revitalization,
and Gentrification (W065)**
CM | 2.5

Monday, 2:15–5:15 p.m.
Transportation: Motorcoach,
walking. **\$55**

**Adaptive Reuse in
Historic Gretna (W043)**
CM | 3

Monday, 2:30–6:00 p.m.
Transportation: Motorcoach,
walking. **\$70**

**Ferries, Bridges, and Bikes
(W064)**
CM | 2.5

Monday, 2:30–6:30 p.m.
Transportation: Ferry, bicycle
(five miles). **\$55**

Mississippi River Trail (W066)
CM | 2.5

Monday, 2:30–5:30 p.m.
Transportation: Bicycle (20
miles). **\$55**

New Orleans East (W067)
CM | 1.5

Monday, 2:30–5:30 p.m.
Transportation: Motorcoach,
walking. **\$55**

TUESDAY, APRIL 13

Uptown Run (W068)
CM | 1

Tuesday, 7:00–9:00 a.m.
Transportation: Running (five
miles). **\$30**

**Tammany Trace Rail-Trail
by Bike (W070)**
CM | 1

Tuesday, 7:15–11:15 a.m.
Transportation: Motorcoach,
bicycle (nine miles). **\$75**

**Tammany Trace Rail-Trail
by Foot (W069)**
CM | 1

Tuesday, 7:15–11:15 a.m.
Transportation: Motorcoach,
running, or walking (2.5 miles).
\$60

**Cajun-Flavored
Ecocultural Tourism (W071)**
CM | 8.5

Tuesday, 8:00 a.m.–6:00 p.m.
Transportation: Motorcoach,
walking. Includes lunch. **\$100**

**Coastal Protection and
Restoration (W072)**
CM | 3.5

Tuesday, 8:00 a.m.–noon
Transportation: Motorcoach,
walking. **\$60**

**Magazine Street Mixed Use
Corridor (W073)**
CM | 3.5

Tuesday, 8:15 a.m.–12:15 p.m.
Transportation: Motorcoach,
walking. **\$60**

**Case Studies in Public
Housing Redevelopment
(W074)**
CM | 3

Tuesday, 8:15–11:45 a.m.
Transportation: Motorcoach,
walking. **\$60**

**Ecosystem Restoration
and Sustainability (W075)**
CM | 3

Tuesday, 8:30 a.m.–noon
Transportation: Motorcoach,
walking. **\$60**

**The Louisiana Superdome
(W076)**
CM | 2

Tuesday, 8:30 a.m.–noon
Transportation: Motorcoach,
walking. **\$60**

Louis Armstrong Park (W077)
CM | 3

Tuesday, 8:45 a.m.–12:15 p.m.
Transportation: Motorcoach,
walking. **\$60**

**The Monumental Task Force
(W078)**
CM | 2.5

Tuesday, 8:45–11:45 a.m.
Transportation: Motorcoach,
walking. **\$55**

**Mississippi Gulf Coast
National Heritage
Area (W079)**
CM | 5

Tuesday, 9:00 a.m.–4:00 p.m.
Transportation: Motorcoach,
walking. Includes lunch. **\$90**

**Baton Rouge Brownfields
Program (W080)**
CM | 5.5

Tuesday, 9:00 a.m.–3:30 p.m.
Transportation: Motorcoach,
walking. Includes lunch. **\$95**

**Tourism and Development
in Coastal Louisiana (W081)**
CM | 5

Tuesday, 9:15 a.m.–3:15 p.m.
Transportation: Motorcoach,
walking. Includes lunch. **\$100**

**Vieux Carre History
and Development (W082)**
CM | 2.5

Tuesday, 9:15 a.m.–12:15 p.m.
Transportation: Motorcoach,
walking. **\$60**

**Planning the Rebuilding
of Schools (W083)**
CM | 2.5

Tuesday, 9:15 a.m.–12:15 p.m.
Transportation: Motorcoach,
walking. **\$60**

**Grassroots Urban
Forestry Programs (W084)**
CM | 3.5

Tuesday, 1:30–5:30 p.m.
Transportation: Motorcoach,
walking. **\$60**

**Brownfields Along the
Mississippi River (W085)**
CM | 3.5

Tuesday, 1:30–4:30 p.m.
Transportation: Motorcoach,
walking. **\$55**

**Main Street's Role
in Recovery (W086)**
CM | 3

Tuesday, 2:00–5:30 p.m.
Transportation: Motorcoach,
walking. **\$60**

Wetlands Explored (W087)
CM | 5

Tuesday, 2:00–7:00 p.m.
Transportation: Motorcoach,
boat. **\$65**



GET THE LATEST

SESSIONS

Sustainability, freight movement, design guidelines, or planning for older adults—select from over 170 sessions tailored to your interests. Whether you're interested in the story of rebuilding in the Gulf or planning for energy, you'll find sessions designed for you.

SUNDAY, 7:30–8:30 A.M.

A Performance-Driven Transportation Vision (S405)
CM | 1

Advances in Signs and Regulation (S406)
CM | 1

AmeriCorps as a Community Planning Resource (S407)
CM | 1

Arizona's Smart Growth Scorecard (S408)
CM | 1

Facilitating Geothermal Heating and Energy (S410)
CM | 1

Measuring Economic Impacts of Scenic Byways (S411)
CM | 1

Missoula Greater Downtown Master Plan (S412)
CM | 1

New York City Active Design Guidelines (S413)
CM | 1

Planning for the Bottom Line (S414)
CM | 1

Regional Foodshed Planning (S415)

CM | 1

Stand Out as a Planner (S416)
CM | 1

Successful County Planning Projects (S417)
CM | 1

Surprising Demographics (S418)
CM | 1

The Right Tools for Defining Place (S419)
CM | 1

SUNDAY, 8:45–10:15 A.M.

Opening Keynote (S700)
CM | 1

SUNDAY, 10:30–11:45 A.M.

A New Energy and Climate Future (S420)
CM | 1.25

Sponsor: APA Green Communities Research Center

Applying Technology to Transit Planning (S421)
CM | 1.25

Sponsor: Technology Division

Leadership in a Creative Environment (S423)

CM | 1.25

Multigenerational Planning (S499)
CM | 1.25

Sponsor: Housing and Community Development Division

New Orleans's 21st Century Master Plan (S424)

CM | 1.25

Sponsor: Local Host Committee

Partnering with Foundations for Added Impact (S425)
CM | 1.25

Resilient Cities for a Post-Carbon World (S426)
CM | 1.25

Suburban Open Space Strategies (S427)
CM | 1.25

Sponsor: Urban Design and Preservation Division

Sustainable Small Town Economic Development (S428)
CM | 1.25

SUNDAY, 10:30–11:45 A.M.

Sustainable Water Recycling (S429)

CM | 1.25

The Job of the Planning Commissioner (S100)

The Transformation of New Lanark (S430)

CM | 1.25

The Transit-Development Debate (S431)

CM | 1.25

University-Community Planning Partnerships (S432)

CM | 1.25

SUNDAY, 12:45–2:15 P.M.

Ethics for Planners and Lawyers (S433)

CM | 1.5 | Ethics

Israel Stollman Symposium

SUNDAY, 1:00–2:15 P.M.

Building Successful Smart Growth Partnerships (S434)
CM | 1.25

Sponsor: Regional and Intergovernmental Planning Division

Comprehensive Zoning Reform in Three Cities (S435)

CM | 1.25

Conservation Easements (S436)
CM | 1.25

Ethics for Planning Officials (S101)

Designing Active Communities for Youth (S437)
CM | 1.25

Sponsor: New Urbanism Division

Graduated Density Zoning (S439)
CM | 1.25

Green Community (S440)
CM | 1.25

How to Fix Your Suburban Downtown (S441)
CM | 1.25

APA PLANNERS PRESS

From downtown planning to urban design, learn about the newest offerings from APA Planners Press. Hear the authors in these intriguing sessions. Attend the book signing in the bookstore in the exhibit hall following each session.

Imagining Better Communities Workshop (W410)

Saturday, 8:00 a.m.–noon

Green Community (S440)

Sunday, 1:00–2:15 p.m.

Grid/Street/Place and Sustainable Urbanism (S451)

Sunday, 2:30–3:45 p.m.

Delta Urbanism Plenary (S701)

Monday, 7:30–8:45 a.m.

Experiencing Post-Katrina Planning in New Orleans (Clear as Mud) (S510)

Monday, 10:30–11:45 a.m.

Downtown Planning for Smaller and Mid-sized Communities (S523)

Monday, 2:30–3:45 p.m.

Leadership Matters (S442)
CM | 1.25

Planners Working Globally (S443)
CM | 1.25

Small Town Stations and TOD (S444)
CM | 1.25

Sustainability in the Midwest (S445)
CM | 1.25

TIF's Past, Present, and Future (S446)
CM | 1.25

Transportation and Density (S447)
CM | 1.25

SUNDAY, 2:30–3:45 P.M.

Affordable Housing Funds in Community Development (S448)
CM | 1.25

Citizen's Guide to Comprehensive and Other Plans (S449)

Creating Your Leadership Stimulus Package (S450)
CM | 1.25

Grid/Street/Place and Sustainable Urbanism (S451)
CM | 1.25

Planning Research on Climate Change: Questions (S452)
CM | 1.25

Sponsor: Journal of the American Planning Association

Making Suburbs Sustainable and Competitive (S453)
CM | 1.25

Mitigation Strategies for Urban Reforestation (S454)
CM | 1.25

Mobility & Community Form (S455)
CM | 1.25

Natural Resource Protection Zoning (S456)
CM | 1.25

Partnering for Successful Neighborhood Redevelopment (S457)
CM | 1.25

Sponsor: Local Host Committee

Station-Area Planning and High-Speed Rail (S458)
CM | 1.25

SUNDAY, 2:30–3:45 P.M.**Public-Private Partnerships Go Green** (S459)

CM | 1.25

*Sponsor: Private Practice Division***Safe Routes to Sustainable Communities** (S460)

CM | 1.25

Sustaining Aging (S461)

CM | 1.2

Planning for Street Food Vendors (S462)

CM | 1.25

*Sponsor: Latinos and Planning Division***SUNDAY, 4:00–5:15 P.M.****Airport Land-Use Compatibility Planning** (S464)

CM | 1.25

Environmental Requirements and Rural Highway Corridors (S465)

CM | 1.25

Big-City Planning Directors (S466)

CM | 1.25

Collaborative Decision Making in Transportation Planning (S467)

CM | 1.25

Cultural Conservation in Louisiana (S468)

CM | 1.25

*Sponsor: Local Host Committee***Engaging Low-Income Communities of Color** (S469)

CM | 1.25

From Boomburg to Build Out (S470)

CM | 1.25

Incorporating Science into Community Plans (S471)

CM | 1.25

Planning Research on Climate Change: Lessons (S472)

CM | 1.25

*Sponsor: Journal of the American Planning Association***Planning for Arts and Entertainment** (S473)

CM | 1.25

Planning for Regional Mobility (S474)

CM | 1.25

Siting a Wind Farm (S476)

CM | 1.25

*Sponsor: County Planning Division***The Multiple Dimensions of Planning and Disasters** (S477)

CM | 1.25

Urban Design Reclaimed (S478) CM | 1.25**Working Successfully with Tribes and Pueblos** (S479)

CM | 1.25

*Sponsor: Indigenous Planning Division***SUNDAY, 5:30–7:00 P.M.****A Bull Market for Wetlands** (S480)

CM | 1.5 | Law

*Bettman Symposium***Fast, Funny, and Passionate Planning Presentations** (S482)

CM | 1.25

Leveraging High-Speed Rail for Urban Planning (S608)

CM | 1.25

ADA Compliance (S483)

CM | 1.25

Disaster-Resilient Tribal Communities (S485)

CM | 1.25

Elements of Sustainability Planning Approach (S486)

CM | 1.25

Evaluation Methods for Public Facilities (S487)

CM | 1.25

Land-Use Opportunities for Foreclosures (S488)

CM | 1.25

Urban Corridor Planning Initiative (S489)

CM | 1.25

MONDAY, 7:30–8:45 A.M.**Delta Urbanism****Plenary Session** (S701)

CM | 1

MONDAY, 9:00–10:15 A.M.**Green Streets** (S490)

CM | 1.25

*Cosponsor: American Institute of Landscape Architects***Community Conservation and Cultural Tourism** (S491)

CM | 1.25

Customizing Design Guidelines to Community Needs (S492)

CM | 1.25

Federal Economic Recovery and Development Funding (S493)

CM | 1.25

Retaining a Consultant (S494)

CM | 1.25

The Future of the Housing Market (S495)

CM | 1.25

Innovative Intersection Design (S496)

CM | 1.25

Measurable Outcomes in Planning (S498)

CM | 1.25

Retrofitting Suburban Centers and Corridors (S500)

CM | 1.25

Rural and Small Town Design Guidelines (S501)

CM | 1.25

*Sponsor: Small Town and Rural Planning Division***Sustainable Water Strategies in a Changing Climate** (S502)

CM | 1.25

*Sponsor: Environment, Natural Resources, and Energy Division***Transportation Strategies for Reducing Greenhouse Gas** (S503)

CM | 1.25

Unconventional Approaches to Public Involvement (S504)

CM | 1.25

MONDAY, 10:30–11:45 A.M.**21st Century Urban Industrial Strategies** (S505)

CM | 1.25

Culture, Politics, and Black Leadership in Planning (S506)

CM | 1.25

*Sponsor: Planning and the Black Community Division***Dealing with Nonconformities in a Down Economy** (S507)

CM | 1.25

*Sponsor: Zoning Practice***Engaging the Public Using Technology** (S509)

CM | 1.25

Experiencing Post-Katrina Planning in New Orleans (S510)

CM | 1.25

Integrating Green Infrastructure into Regional Planning (S511)

CM | 1.25

Louisiana Land-Use Toolkit (S512)

CM | 1.25

Making the Case for Density (S513)

CM | 1.25

Managing Complex Relationships in Planning (S102) CM | 1.25

CM | 1.25

Revisiting Pedestrian Malls (S514)

CM | 1.25

Rural Planning Perspectives (S515)

CM | 1.25

Streetcars, Rail, and TOD in New Orleans (S516)

CM | 1.25

*Sponsor: Local Host Committee***Student and New Planner Career Roundtable** (S517)

Photo Courtesy of New Orleans Convention and Visitors Bureau

**Technology Showcase**

Hear about the latest technology for planning tools and techniques. One-hour sessions end with 15 minutes for hands-on exploration so you can try out the software or technology tool yourself.

Objective Land Development Evaluation (S201)

CM | 1

Saturday, 1:00–2:00 p.m.

Taking Walkability and Health Online (S202)

CM | 1

Saturday, 2:30–3:30 p.m.

HAZUS for Risk Analysis (S205)

CM | 1

Sunday, 2:30–3:30 p.m.

Measuring “Build Out” to Support Planning (S207)

CM | 1

Monday, 9:00–10:00 a.m.

The Planners’ Bibliography Web Tool (S208)

CM | 1

Monday, 10:30–11:30 a.m.

Lights, Camera, Planning! (S209)

CM | 1

Monday, 2:30–3:30 p.m.

Utilizing Integrated Models (S210)

CM | 1

Monday, 4:00–5:00 p.m.

Measuring Social Equity in Transportation (S211)

CM | 1

Tuesday, 9:00–10:15 a.m.

Using GIS to Encourage Walking and Biking (S212)

CM | 1

Tuesday, 10:30–11:45 a.m.



John Reinhardt

©istockphoto.com

©istockphoto.com/tukasz Zakrzewski

Delta Urbanism Symposium

Climate change is affecting coastal areas around the world, and no more dramatically than in delta regions. Many of the largest cities in the world are located in deltas. However, these attractive places to live are vulnerable to natural disasters whose magnitude appears to increase with climate change.

With the Mississippi Delta as a laboratory, the Delta Urbanism Symposium explores the growth, development, and management of cities in river deltas around the world, with a spotlight on solutions for balancing various—and often competing—goals: urbanization, economic development, flood defense, public safety, ecological balance, and quality of life. The symposium highlights the policies, tools, technology, coordinated planning, public outreach, and international cooperation—both current and emerging—to manage the future of all coastal cities. *Sponsors: Lincoln Institute of Land Policy, National Oceanic and Atmospheric Administration, and the Royal Netherlands Embassy. Cosponsors: APA Green Communities Research Center and APA Hazards Planning Research Center.*

SATURDAY

Delta Urbanism and Water Cities (S400)
CM | 1.25

9:00–10:15 a.m.

Linking Climate Change Science with Policy and Planning (S401)
CM | 1.25

10:30–11:45 a.m.

Climate Adaptation Planning in Delta Regions (S402)
CM | 1.25

1:00–2:15 p.m.

Case Studies of European Deltas (S403)
CM | 1.25

2:30–3:45 p.m.

Preparedness and Recovery Planning in Delta Regions (S404)
CM | 1.25

4:00–5:15 p.m.

SUNDAY

Prescription for Safe Delta Development (S475)
CM | 1.25

7:30–8:30 a.m.

GIS and Delta Urbanism (W204)
CM | 1.5

10:00–11:30 a.m.

\$25

Dutch Dialogues (S422)
CM | 1.25

10:30–11:45 a.m.

Making New Orleans Resilient (W009)
CM | 2.5

10:30 a.m.–1:30 p.m.

\$65

Case Studies of Asian Deltas (S484)
CM | 1.25

10:30–11:45 p.m.

Federal Partnerships and Sustainable Communities (S438)
CM | 1.25

1:00–2:15 p.m.

Managing Water with Blueways (W028)
CM | 2.5

1:45–4:45 p.m.

\$55

Is There a Unique Delta Urbanism? (S463)
CM | 1.25

2:30–3:45 p.m.

Engineering and Planning as Flood Defense (S409)
CM | 1

4:00–5:15 p.m.

MONDAY

Life, Death, and Rebirth of Louisiana's Coast (W034)
CM | 7.5

7:30 a.m.–3:30 p.m.

\$95

Louisiana Wetlands Restoration and Renewal (S497)
CM | 1.25

9:00–10:15 a.m.

Energy, Climate Change, and Security (S508)
CM | 1.25

10:30–11:45 a.m.

Flood Protection Choices in New Orleans (W059)
CM | 3

1:30 p.m.–5:00 p.m.

\$60

Yancheng's Plan for Coastal Development and Environmental Management (S532)
CM | 1.25

2:30–3:45 p.m.

GIS and Delta Urbanism (W210)
CM | 1.5

3:00–4:30 p.m.

\$25

Environmental Restoration and MRGO (S535)
CM | 1.25

4:00–5:15 p.m.

Integrated Coastal Zone Planning (S552)
CM | 1.25

5:30–6:45 p.m.

TUESDAY

Building the Digital Coast (S560)
CM | 1.25

7:30–8:45 a.m.

Coastal Protection and Restoration (W072)
CM | 3.5

8:00 a.m.–noon

\$60

Reducing Climate Impacts in Developing Nations (S573)
CM | 1.25

9:00–10:45 a.m.

International Collaboration in Delta Regions (S592)
CM | 1.25

10:30–11:45 a.m.

Wetlands Explored (W087)
2:00 p.m.–7:00 p.m.
\$65

MONDAY, 10:30–11:45 A.M.

The Real Meaning of Sustainability (S518)

CM | 1.25

Sponsor: Planning

MONDAY, 2:30–3:45 P.M.

Canadian Mobility Hubs and Urban Centres (S519)

CM | 1.25

Charting the Port of New Orleans's Future (S520)

CM | 1.25

Sponsor: Local Host Committee

Context-Sensitive Affordable Housing (S521)

CM | 1.25

Diversity Forum (S522)

CM | 1.25

Downtown Planning for Smaller and Midsized Communities (S523)

CM | 1.25

Global Lessons in Sustainability (S524)

CM | 1.25

Sponsor: International Division

Implementing California's Climate Change Legislation (S525)

CM | 1.25

Integrating Hazard Mitigation into Local Planning (S526)

CM | 1.25

Land Use in Changing Financial Times (S527)

CM | 1.25

Nonprofits Make Good Brownfields Partners (S528)

CM | 1.25

Planning Policies for Urban Agriculture (S529)

CM | 1.25

Progressive Place-Based Planning in College Towns (S530)

CM | 1.25



Photo Courtesy of New Orleans Convention and Visitors Bureau

Poster Sessions

Learn about the latest research, innovative projects, and effective programs. All poster presenters will be available on **Sunday from noon to 2:00 pm** to discuss their project and posters. Don't miss this opportunity for an in-depth conversation and to see where planning is headed.

3-D Land Use (S301)

A Hedonic Regression Model for Economic Development (S302)

Accessory Dwellings in L.A.'s Suburbs (S303)

America's Marine Highway Program (S304)

Beach Lighting Ordinances and Sea Turtle Protection (S305)

Bicycle and Pedestrian Access in D.C. (S306)

BRT and the 2016 Olympics (S307)

Classic Towns of Greater Philadelphia (S308)

Community Participation in Earthquake Reconstruction (S309)

Complexities of Food System Planning (S310)

Consistency Under the Microscope (S311)

Developing a BRT Strategic Plan (S312)

Friend Me (S313)

Harnessing Students' Energy and Enthusiasm (S314)

Heritage Tourism and Scenic Byways Planning (S315)

Improving Pedestrian Thermal Comfort (S317)

Improving Walkability for Seniors (S318)

Leading the Sustainable Zoning Charge (S319)

Mapping Bicycle Infrastructure (S320)

Neighborhood Investment: Selling It by Telling It (S321)

North Temple Boulevard's Transformation (S322)

Planning in Rural and Indigenous Communities (S323)

Regional and Small-Area Forecasting (S324)

Regional Planning Comes Full Circle (S325)

Remapping Flood Hazards (S326)

Rural Mixed Use Land-Use Centers (S327)

Slugging to Work (S328)

TOD in Japan and the USA (S329)

Urban Farming in the Built Out City (S330)

Using Data-Driven Decision Making (S331)

Student Posters

A Food Policy Audit Guide (S350)

Addressing Socioeconomic Vulnerability to Hurricanes (S351)

Army Water Sustainability (S352)

Buffalo's Community Gardens (S353)

Changing Families, Changing Needs (S354)

Community Resilience and Recovery (S355)

Connecting Creativity and Community Development (S356)

Demographic Analysis in Green Space Accessibility (S357)

Employing Metrics of Sustainability (S358)

Farmland Preservation in Massachusetts (S359)

Green Infrastructure Solutions to Stormwater Runoff (S360)

Greenhouse Gas Emissions Inventory (S361)

Impacts of Fare Pricing (S362)

Kansas Regional Coordinated Transit Pilot Study (S363)

Keeping Alleyways Clean and Clear (S364)

Long-Term Resilience in Southern Louisiana (S365)

Mapping Land Preservation in the Triangle (S366)

Modeling Affordable Housing (S367)

Neighborhood Organizing Works (S368)

Planning Community Resilience to Hazards (S369)

Regional Trends in Urban Rainwater Harvesting (S370)

Resilient Freight Transportation Systems (S371)

Strategies for Waste and Water (S372)

Sustainability in the Transportation Planning Process (S373)

The Economics of Form-Based Codes (S374)

The Travel-Toll Relationship (S375)

Unmet Housing Needs During Disaster (S376)

Urban Design and Security (S377)

What is an Engaged University? (S378)

MONDAY, 2:30–3:45 P.M.

Street Design and the Fire Code (S531)

CM | 1.25

Sustainability in Discretionary Review (S103)

MONDAY, 4:00–5:15 P.M.

Amtrak Master Plan and High-Speed Rail (S607)

CM | 1.25

CEOs on the State of the Landscape Architecture and Planning Professions (S533)

CM | 1.25

Cosponsor: American Society of Landscape Architects

Cold Cash for Bonus Densities (S534)

CM | 1.25

Ethnicity, Religion, and New Orleans's Development (S536)

CM | 1.25

Sponsor: Local Host Committee

Integrating Professionals into Academic Curriculum (S537)

Sponsor: Planning Accreditation Board

Housing Density and Transportation Near Job Centers (S538)

CM | 1.25

Natural Systems and Landscape Scale Analysis (S539)

CM | 1.25

Parking Management Innovations (S540)

CM | 1.25

Planning for Sustainable Communities (S541)

CM | 1.25

Retrofitting Commercial Strip Corridors (S542)

CM | 1.25

Riding Out the Recession (S543)

CM | 1.25

Sponsor: Economic Development Division

Rural Land Use and Transportation Coordination (S544)

CM | 1.25

Sustainable Freight Movement in Metropolitan Areas (S545)

CM | 1.25

Sponsor: Transportation Planning Division

TOD Momentum on the Corridor Level (S547)

CM | 1.25

MONDAY, 5:30–7:00 P.M.

Pecha Kucha–Style Event: The Great American Suburb (S548)

CM | 1.25

Ethics and Sustainability (S549)

CM | 1.5 | Ethics

Resetting the Public-Private Power of Planning (S550)

CM | 1.5 | Law

Bettman Symposium

MONDAY, 5:30–6:45 P.M.

Demystifying Floodplain Management Data (S551)

CM | 1.25

Integrating Planning into Highway Design (S553)

CM | 1.25

Leadership in the AIP/ASPO Merger (S554)

CM | 1.25

Neighborhoods and University in Partnership (S555)

CM | 1.25

Planning in the Atchafalaya National Heritage Area (S595)

CM | 1.25



Joe Szurzewski

Facilitated Discussions

These popular, more intimate, discussion-focused events are back with even more options. Whether you are a new professional or seasoned planner, you'll find a discussion geared to your interests.

Planning Director	Student
Planning Department Management Challenges (S800) CM 1.25 Sunday, 2:30–3:45 p.m.	Working in the Firm (S802) Sunday, noon–1:00 p.m.
Metropolitan Planning Organization Structure and Staffing (S814) CM 1.25 Tuesday, 10:30–11:45 a.m.	Planners
Planning Commissioner	Turning Passions into Productive Energy (S803) CM 1 Sunday, noon–1:00 p.m.
Achieving Consensus Among Commissioners (S801) Monday, 10:30–11:45 a.m.	Planning for Wind Energy (S808) CM 1.25 Monday, 9:00–10:15 a.m.
New Professional	Working Where Planning Is Not King (S805) CM 1.25 Sunday, 10:30 a.m.–11:45 a.m.
Public vs. Private Sector Employment (S804) CM 1.25 Sunday, 1:00–2:15 p.m.	Sustainability Managers' Discussion (S811) CM 1 Monday, 4:00–5:15 p.m.
Leadership Experience Through APA Involvement (S806) CM 1.25 Sunday, 4:00–5:15 p.m.	Social Media in Planning (S809) CM 1.25 Monday, 5:30–6:45 p.m.
Urban Design and Planning within Multidisciplinary Firms (S807) CM 1.25 Sunday, 5:30–6:45 p.m.	Latino Outreach (S812) CM 1.25 Tuesday, 7:30–8:45 a.m.
Planning Grads in Engineering Firms (S810) Monday, 2:30–3:45 p.m.	Transforming APA's Information Strategy (S813) Tuesday, 9:00–10:15 a.m.

MONDAY, 5:30–6:45 P.M.

Sustainable Urban Tourism (S556)
 CM | 1.25

What Models Can Do for You (S557)
 CM | 1.25

Economic Childcare in Disaster and Recovery (S610)
 CM | 1.25

TUESDAY, 7:15–8:45 A.M.

Planning for the Worst-Case Scenario (S558)
 CM | 1.5 | Law

Sponsor: Planning and Law Division

Ethical Responsibility to Social Equality (S606)
 CM | 1.5 | Ethics

TUESDAY, 7:30–8:45 A.M.

A Rapid Rise in U.S. Biking (S559)
 CM | 1.25

Complete Streets Policies and Implementation (S561)
 CM | 1.25

Everything You Need to Know about Proformas (S562)
 CM | 1.25

U.S. Army Corps of Engineers Hazard Mitigation Planning (S563)
 CM | 1.25

Sponsor: Federal Planning Division

From Suburban to Urban in Canada (S564)
 CM | 1.25

General Plans as a Management Tool (S565)
 CM | 1.25

Mixed Use Zoning and TOD (S566)
 CM | 1.25

Planning Directors in the Hot Seat! (S567)
 CM | 1.25

Planning for Local Business Recovery (S568)
 CM | 1.25

Portland's River Plan (S596)
 CM | 1.25

Resilient Design with Climate in Mind (S569)
 CM | 1.25

Successful Land Acquisition Programs (S570)
 CM | 1.25

Transportation and Food Access (S571)
 CM | 1.25

TUESDAY, 9:00–10:15 A.M.

Affordable Housing Recovery in New Orleans (S574)
 CM | 1.25

Sponsor: Local Host Committee

Planning Law of the Past Year (S575)
 CM | 1.25

Community Voices and Visions (S577)
 CM | 1.25

Community Education and Engagement (S576)
 CM | 1.25

Sponsor: City Planning and Management Division

Energy Planning and Funding (S578)
 CM | 1.25

Fiscal and Social Impacts of Form-Based Codes (S579)
 CM | 1.25

Free Web 2.0 Applications for Planning (S580)
 CM | 1.25

Growing Forward After Jobs Leave Town (S581)
 CM | 1.25

Joint Use of Existing Facilities (S582)
 CM | 1.25

Leading from the Middle (S583)
 CM | 1.25

Sponsor: Planning and Women Division

Partnering to Improve Electric Facility Siting (S584)
 CM | 1.25

Planner Skills, Preparation, and Job Success (S585)
 CM | 1.25

Cosponsor: Planning Accreditation Board

Rethinking Urban Freeways (S586)
 CM | 1.25

Rules that Shape Tomorrow (S587)
 CM | 1.25

TUESDAY, 10:30–11:45 A.M.

An Online Toolbox to Address Climate Change (S588)
 CM | 1.25

Can Planning Policies Produce Quality Design? (S589)
 CM | 1.25

Emergent Responsibilities in Economic Planning (S590)
 CM | 1.25

Implementing Community Assistance Programs Within APA (S591)
 CM | 1.25

Living Below Sea Level (S593)
 CM | 1.25

Sponsor: Local Host Committee

Looking Past Market Cycle Pressures (S594)
 CM | 1.25

Preserve Rural Character While Balancing Growth (S597)
 CM | 1.25

Reshaping Suburbs as Walkable Urban Places (S598)
 CM | 1.25

TUESDAY, 10:30–11:45 A.M.

Making Suburban Corridors into Meaningful Public Spaces (S599)
CM | 1.25

Secrets to Improve Client-Consultant Relations (S600)
CM | 1.25

Sustainability, Carbon Reduction, and Renewable Energy (S601)
CM | 1.25

Sustainable University-City Redevelopment Partnerships (S602)
CM | 1.25

Using Sustainability Indicators to Prompt Action (S603)
CM | 1.25

When Disaster Strikes Is Everyone Equal? (S604)
CM | 1.25

Sponsor: Gays and Lesbians in Planning Division

Youth Map New Orleans's Future (S605)
CM | 1.25

TUESDAY, NOON–1:00 P.M.

Closing Keynote (S702)
CM | 1



Meghan Stromberg

Tracks

Tracks focus on current topics and trends. Examine issues in depth while seeing all facets of problem solving.

Tracks are just one choice. Use the web tools to find model itineraries or all events by topic or keyword.

ECONOMIC DEVELOPMENT AND REDEVELOPMENT FINANCING

There are new opportunities for economic development, despite the recession. Explore the role of redevelopment in recovery.

THE FUTURE OF SMALL TOWNS AND RURAL AREAS

Learn how small towns and rural areas are planning for the future in an urbanizing world.

CLIMATE CHANGE, SUSTAINABILITY, AND GREEN COMMUNITY

Find out how planning is producing greener communities and how collaboration furthers sound planning for climate change.

PLANNING MANAGEMENT AND LEADERSHIP

Lead effectively as you learn to manage today's planning agency or firm.

RULES THAT GIVE URBAN FORM

Examine the regulations, templates, guidelines, and codes planners use to shape urban form. *Sponsor: Zoning Practice*

SUBURBAN DESIGN AND RETROFITTING

Explore how suburbs rebuild and evolve into new communities.

TRANSPORTATION AND DENSITY

Transportation and density policies are at the top of the list to address climate change. Learn what's happening now and what planners need to do next.



Joe Szurzewski

PLANNING EXPO

MEET AND GREET

Find out about APA programs, see the latest products and services, and meet colleagues at the Planning Expo. Held at the Morial Convention Center: Hall A.

Saturday, April 10 | 10 a.m.–4 p.m.

Sunday, April 11 and Monday, April 12 | 7:30 a.m.–4:00 p.m.

Exhibitors

Check out the latest products and services at more than 100 booths. Refreshments will be available.

APAPlanningBooks.com

Be the first to see hot-off-the-presses books from APA Planners Press and meet the authors at the book signings. Stock up on classic titles and try out CD-ROM training packages. Take advantage of conference-only special deals.

APA Job Connection

Find the right person for the job or the right job for you. Employers: Post your open positions on the Job Connection website before the conference and reserve interview rooms at the conference. Job Seekers: If you are an APA member and plan to attend the conference, visit the Job Connection website to find open positions.

APA Cyber Center

Stop by the APA Cyber Center to check and send e-mail. Use your temporary conference e-mail account (log in using your APA ID and password) or your personal web-based e-mail account.

Morial Convention Center

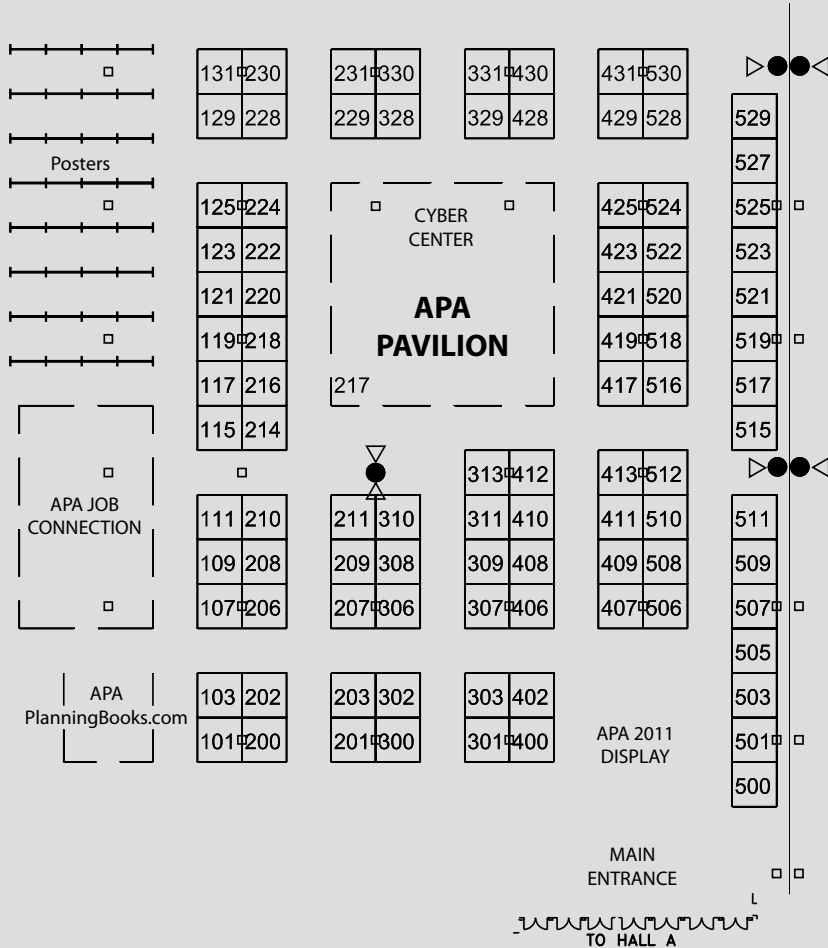

Sign on as an exhibitor and you will have three days to market your products and services through personal contact with thousands of professional planners and planning officials.

Visit www.planning.org/conference/expo/exhibitors.htm for more information.



Meghan Stromberg

REGISTER FOR APA'S NATIONAL PLANNING CONFERENCE TODAY!

Easy online registration: www.planning.org/conference

With hundreds of sessions, workshops, mobile workshops, and networking opportunities, APA's 2010 National Planning Conference is the conference of the year. With thousands of planners and planning officials from around the world in attendance, it's the place to be in 2010. Reserve your spot at the world's premier planning event today.

Registration

As part of our organization-wide effort to be more environmentally conscious, we have eliminated paper registration forms from this conference program. You can register for the conference on our new and improved conference website: www.planning.org/conference.

On the website, you'll find full details on all the conference activities and a new, interactive way to browse the conference program. You can build a personalized schedule or simply go straight to our streamlined registration page. Remember, APA members pay discounted rates for the conference. Be sure to have your APA ID on hand when you register.

SAVE BIG WHEN YOU REGISTER BY FEBRUARY 18!

Payment must be received at APA by:

	Feb. 18	Mar. 11	On-site
--	---------	---------	---------

Conference-only rate
Includes full conference (Sunday-Tuesday), and awards luncheon invitation

APA Regular Member/Planning Board Member	\$595	\$645	\$695
Nonmember	\$895	\$945	\$995
APA Student/Retired/Life Member	\$100	\$120	\$140
APA New Professional Member	\$295	\$295	\$295
Speaker	\$595	\$645	\$695

Saturday-only Training Workshops

Half-Day Workshop	\$150	\$150	\$150
Full-Day Workshop	\$295	\$295	\$295
Institutes	\$395	\$395	\$395

Conference Bundled Rate

Includes full conference, awards luncheon invitation, and one full-day or two half-day training workshops or one full-day institute

APA Regular Member/Planning Board Member/ Speaker (workshops)	\$845	\$895	\$945
APA Regular Member/Planning Board Member/ Speaker (institutes)	\$945	\$995	\$1045

Pre-Registration Deadline: Thursday, March 11, 2010

Housing

Reserve your hotel room for the APA conference through our partner, Travel Technology Group, and book at the lowest rates available. Reservations accepted by phone, fax, mail, or online. Most conference sessions will be held at the Ernest N. Morial Convention Center. Shuttle service will not be available.

Find a complete list of conference hotels and other information online at www.planning.org/conference.

Child Care

APA will provide child care for the children of registered participants for \$30 per day, regardless of the number of hours or children. Please indicate when registering for the conference if you would like to have child care. If APA does not have 10 children registered for child care by February 18, this service will be cancelled. For more details, e-mail jkrol@planning.org. **Registration deadline is February 18.**

Conference Hotels

Hilton New Orleans Riverside

*Headquarters Hotel

2 Poydras St.
(1 block to Convention Center)
\$219

Courtyard New Orleans Convention Center by Marriott

300 Julia St.
(2 blocks to Convention Center)
\$169

Hotel Monteleone New Orleans

214 Royal St.
(1 mile to Convention Center)
\$199

Loews New Orleans Hotel

300 Poydras St.
(3 blocks to Convention Center)
\$209

New Orleans Marriott at the Convention Center

859 Convention Center Blvd.
(1 block to Convention Center)
\$209

Renaissance Arts Hotel

700 Tchoupitoulas St.
(4 blocks to Convention Center)
\$199

SpringHill Suites New Orleans Convention Center by Marriott

301 St Joseph St.
(2 blocks to Convention Center)
\$169



Photo Courtesy of New Orleans Convention and Visitors Bureau/Richard Nowitz

GET TOGETHER

MEETINGS AND RECEPTIONS

Get together with friends and colleagues. Connect with planners who share your interests at a division meeting or alumni gathering.

Division Meetings and Events

Unless otherwise noted, most of the following division events will be held at the Hilton New Orleans Riverside. Please note exact room locations in the final program.

Gays and Lesbians in Planning Division Annual Reception (X001)

Saturday, 6:00–8:00 p.m.
Event will be held at Napoleon's Itch.

Housing and Community Development Division Annual Business Meeting (X002)

Sunday, 11:45 a.m.–1:00 p.m.

International Division Student International Forum (X004)

Sunday, 11:45 a.m.–1:00 p.m.

Planning and the Black Community Division Business Meeting (X005)

Sunday, 11:45 a.m.–1:00 p.m.

Urban Design and Preservation Division Annual Business Meeting (X006)

Sunday, 11:45 a.m.–1:00 p.m.

City Planning and Management Division Business Meeting (X007)

Sunday, 11:45 a.m.–12:45 p.m.

County Planning Division Annual Meeting (X008)

Sunday, 11:45 a.m.–12:45 p.m.

Planning and Women Division Business Meeting (X009)

Sunday, noon–1:00 p.m.

Environment, Natural Resources, and Energy Division Meeting (X010)

Monday, 6:00–7:00 a.m.

Federal Planning Division Business Meeting (X011)

Monday, 6:00–7:00 a.m.

Indigenous Planning Division Meeting (X012)

Monday, 6:30–8:30 p.m.

Latinos and Planning Division Business Meeting (X013)

Monday, 6:30–8:30 p.m.

New Urbanism Division Meeting (X014)

Monday, 6:30–8:30 p.m.

Private Practice Division Business Meeting (X015)

Monday, 6:30–8:30 p.m.

Small Town and Rural Planning Division Business Meeting (X017)

Monday, 6:30–8:30 p.m.

Regional and Intergovernmental Planning Division Meeting (X016)

Monday, 6:30–8:00 p.m.

Economic Development Division Annual Meeting & Reception (X018)

Monday, 6:30–8:00 p.m.

International Division Annual Meeting (X019)

Monday, 6:30–7:30 p.m.

Planning and Law Division Business Meeting & Reception (X020)

Monday, 6:30–7:30 p.m.

Transportation Planning Division Business Meeting and Reception (X021)

Monday, 6:30–7:30 p.m.

Gays and Lesbians in Planning Division Business Meeting (X022)

Monday, 6:30–7:15 p.m.

Gays and Lesbians in Planning Division Annual Dinner (P201)

Monday, 7:30–10:30 p.m.
Event will be held at Tomatillo's. **\$35**

International Division Dinner on the Town (X023)

Monday, 8:00–10:00 p.m.

Cafe au Lait and the International Division (X024)

Tuesday, 6:00–7:00 a.m.

Other Meetings and Events

Association of Collegiate Schools of Planning Governing Board Meeting (X100)

Saturday, 8:00 a.m.–5:00 p.m.

Food Systems Planning Social Event & Film Screening (X051)

Saturday, 6:30–9:30 p.m.

Planners' Prayer Breakfast (P200)

Sunday, 7:00–8:15 a.m.

\$45

Planning Accreditation Board General Meeting and School Reviews (X101)

Sunday, 8:00 a.m.–5:00 p.m.

Public Engagement Network Meeting (X103)

Sunday, 11:45 a.m.–1:00 p.m.

American Society of Consulting Planners (ASCP) Board Meeting (X104)

Sunday, 5:00–6:30 p.m.

Planning Accreditation Board General Meeting and School Reviews (X105)

Monday, 8:00 a.m.–5:00 p.m.

JAPA Editorial Advisory Board Meeting (X106)

Monday, 10:15–11:30 a.m.

Sustainable Community Planning New Interest Group Gathering (X107)

Monday, 6:30–8:30 p.m.

Combined University Alumni Reception (X108)

Monday, 6:30–8:00 p.m.

Complimentary for conference attendees. To include your school in the cash bar reception, e-mail dalongi@planning.org.

All-Iowa Reception (X112)

Monday, 7:00 p.m.

University of Oklahoma Reception (X109)

Monday, 7:00–9:00 p.m.

Georgia Tech City Regional Planning Program and Georgia Planning Association (X110)

Monday, 7:00–8:30 p.m.

University of Illinois at Urbana-Champaign, University of Illinois at Chicago, and APA Illinois Chapter Reception (X111)

Monday, 7:00–8:30 p.m.

Big savings if you register by February 18

© istockphoto.com/Rebecca Bagdanoff



SIGHTSEEING TOURS

The Big Easy. Sightseeing tours by The Vega Group will introduce you to the local color—like the Garden District—and the areas top attractions. A great option for the whole family.

To make reservations, print the form at www.planning.org, fill it in, and send it by mail or fax with your payment information to The Vega Group. Space is limited and advance reservations and ticket purchases are required. The deadline for reservations, changes, cancellations, and requests for full refunds is March 11, 2010. See the reservation form for complete details.

If you have questions about a tour or have any special needs, contact The Vega Group at (504) 488-5222, Monday through Friday, 9:30 a.m.–5:00 p.m. (CDT), or by e-mail at apa2010@vega-group.com.

All tours will depart from and return to the Morial Convention Center. Tickets must be picked up at The Vega Group tour desk in the lobby area at least one hour prior to the tour departure time.

For sold-out tours, a first-come, first-served waitlist will be available at The Vega Group Tour Desk starting one hour prior to the tour departure time. If a tour does not meet the minimum number of guests required to operate, The Vega Group reserves the right to cancel the tour and issue a full refund.

SATURDAY

City Tour—New Orleans in All Her Splendor (V001)

1:30–4:30 p.m.

Transportation: Motorcoach, walking. **\$29**

SUNDAY

City Tour—New Orleans in All Her Splendor (V002)

9:00 a.m.–noon

See Vega Tour V001 for details. **\$29**

Plantation Tour (V003)

9:00 a.m.–2:00 p.m.

Transportation: Motorcoach, walking. Includes lunch. **\$67**

Swamp Tour (V004)

12:30–5:00 p.m.

Transportation: Motorcoach, covered boat. **\$52**

MONDAY

Garden District Tour (V005)

9:00–12:30 p.m.

Transportation: Motorcoach, walking. **\$38**

Plantation Tour (V006)

9:00 a.m.–2:00 p.m.

See Vega Tour V003 for details. **\$67**

Swamp Tour (V007)

12:30–5:00 p.m.

See Vega Tour V004 for details. **\$52**

TUESDAY

Cookin' in the Quarter (V008)

9:30 a.m.–1:30 p.m.

Transportation: Motorcoach. Includes lunch. **\$62**



American Planning Association

Making Great Communities Happen

122 South Michigan Avenue
Suite 1600
Chicago, IL 60603

Nonprofit Organization
U.S. Postage

PAID

Permit No. 307
Carol Stream, Illinois

Important Dates | 2010 National Planning Conference

January 7 Conference scholarship applications due.

February 2 Exhibit/sponsorship application due.

February 18 Early registration deadline.
Child Care Registration Deadline.

March 9 Student volunteer applications due.

March 11 Pre-Registration ends.
Deadline for hotel reservations.
Last day for refunds or exchanges.

April 10 Conference begins.

For more information on these deadlines visit www.planning.org/conference